



# LandPRO

## LP14, LP18

### SHOWN WITH OPTIONAL EQUIPMENT

Wide load lights.



Chassis is steel shot blasted, painted with PPG industrial coating and oven-baked for 75 minutes at 145 degrees.

The tilt indicator is easily seen by the operator.



Turf Tires for better tire wear.

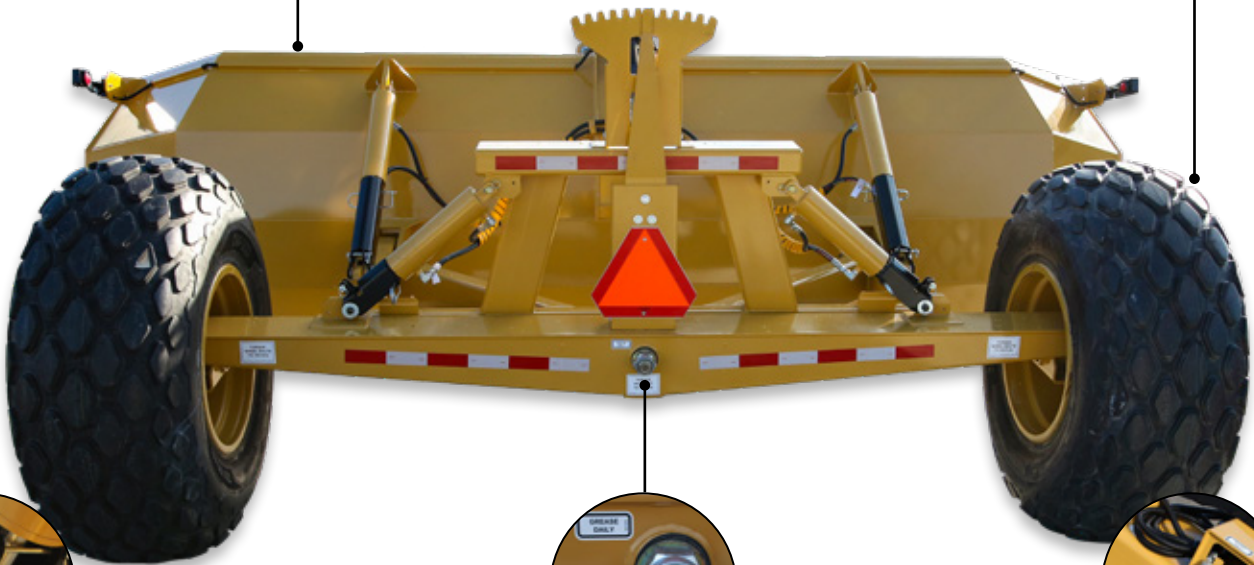

Safety stops on all cylinders prevent damage to the cylinders and the machine while transporting.



Greaseable pivot.



Hydraulic hose storage.



Rev. 0



# D I F F E R E N T B Y D E S I G N

29 Hawkins Road, Centreville, NB E7K 1A4 · T 506 276-4567 · F 506 276-4380 · sales@bwstrailers.com

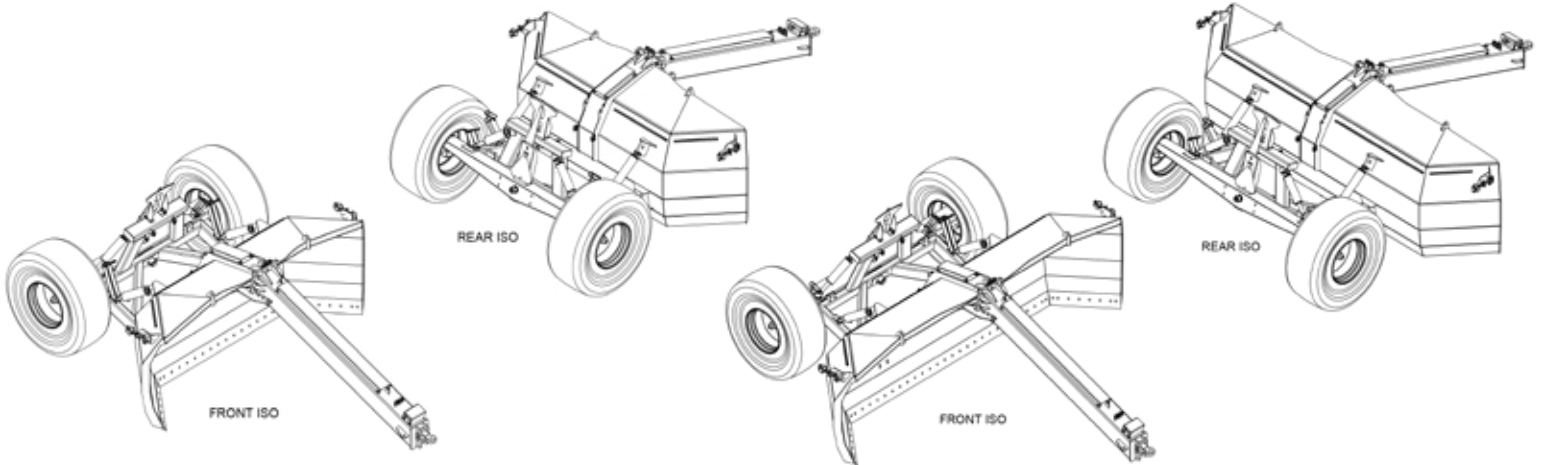

**MODEL: LP14**

14 FT. LAND BLADE

NOTE: ALL DIMENSIONS ARE LOADED & NOMINAL

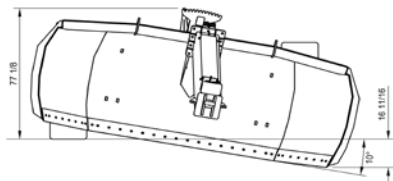
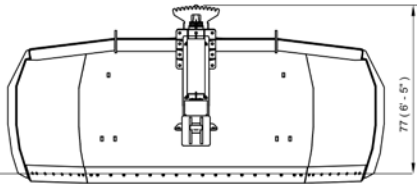
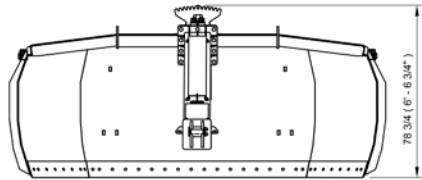
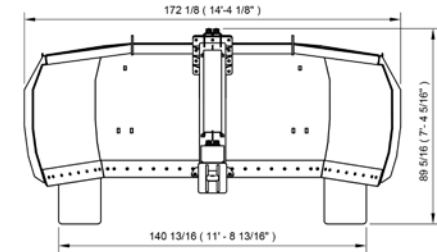

TILT POSITION ( LEFT OR RIGHT ) FRONT  
SCALE 1 / 50

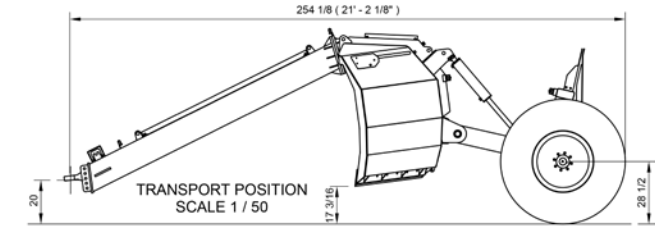

TRANSPORT POSITION  
SCALE 1 / 50

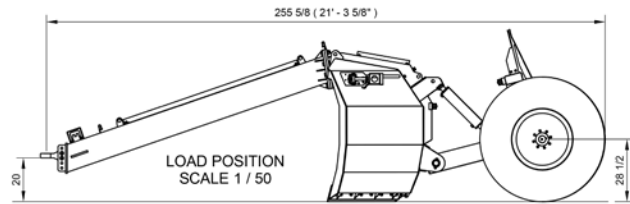

LOAD POSITION  
SCALE 1 / 50

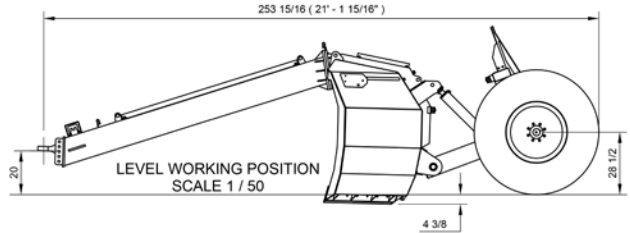

LEVEL WORKING POSITION  
SCALE 1 / 50

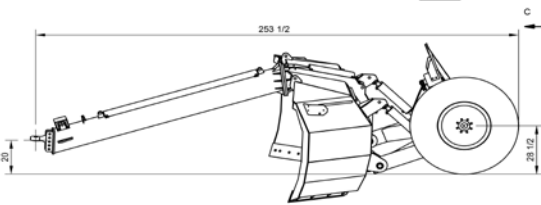

TILT POSITION ( LEFT OR RIGHT ) SIDE  
SCALE 1 / 50

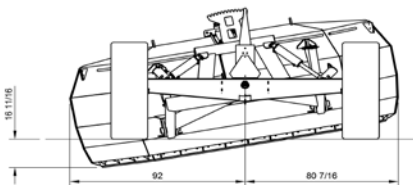

TILT POSITION ( LEFT OR RIGHT ) REAR  
SCALE 1 / 50

**WARRANTY**

**1 YEAR BUMPER TO BUMPER**

• Warrants that the specified BWS equipment will be free from defects in materials and workmanship, under normal use and service, for the period of the first 12 months of regular service post the date-in-service. This warranty extends only to the original first owner. It is not transferable and applies only to OEM installed components and equipment. 100% parts and labour (from the in service date)