

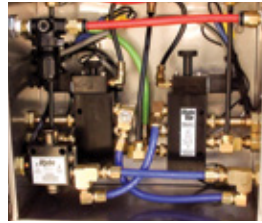

# NFLD B-Train

## 27LBT2XNL, 37LBT3XNL, 46LBT4XNL



Let's face it, we're all working harder today than ever before. So why should you expect anything less from your equipment? Our thoughts exactly. That's why every **BWS** trailer is designed to meet your needs. Our seasoned team of designers and engineers bring together the most innovative technology available to give you a different product, a product that delivers value to you each day, even in extreme environments.



Rev.1



- FEATURES & BENEFITS**
- Certified air powered load binder
  - Air gauge allows operator to be confident when trying to load legal
  - 25,000 lb suspensions with check chains
  - Less downtime even in harsh conditions
  - Fabricated stakes
  - Holland fifth wheel
  - Lift axle on lead
  - Top chain boxes
  - Ladder
  - 5 year structural warranty
  - 3 year paint warranty



D I F F E R E N T B Y D E S I G N

29 Hawkins Road, Centreville, NB E7K 1A4 · Tel: (506) 276-4567 · Fax: (506) 276-4380 · sales@bwstrailers.com

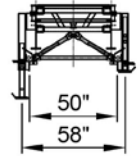
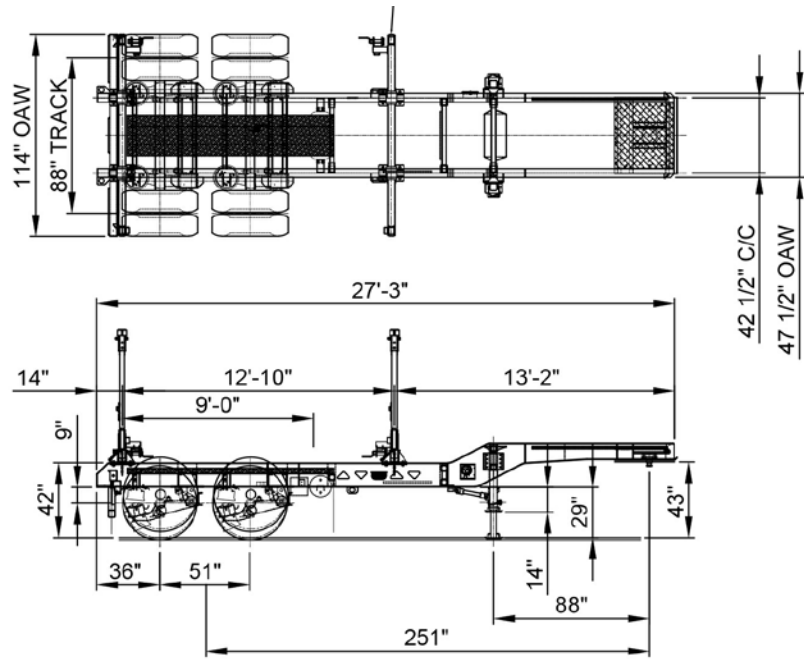
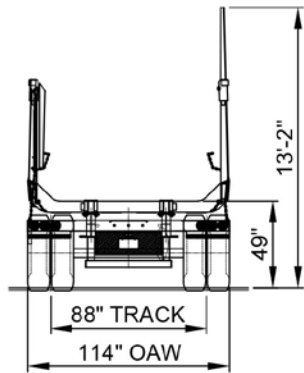

**MODEL: 27LB2X W**  
 27 FT. TANDEM 1 TIER PULL B-TRAIN - WESTERN

Authorised BWS Dealer