



All Season Sander



Rev.1

Let's face it, We are all working harder today than ever before. So why should you expect anything less from your equipment? Every **BWS All Season Sander Body** is designed to meet your needs. Our seasoned team of designers and engineers bring together the most innovative technology available to present a unique product that delivers value to you each day, even in extreme environments.



- FEATURES & BENEFITS**
- Easily convertible.
 - Eliminates costly switchover.
 - Hauls salt, sand, stone, gravel asphalt or mulch.
 - 9' to 16' lengths.
 - Built with hi-tensile steel.
 - Unique inner floor provides additional stability.
 - Spinner can remain on the unit all year or easily detached.
 - Spread width up to 30'.
 - Hinged points are greasable.
 - Front mount telescopic hoist.
 - Multiple speed settings for spinner and conveyor.
 - 5 year structural warranty
 - 3 year paint warranty



D I F F E R E N T B Y D E S I G N

29 Hawkins Road, Centreville, NB E7K 1A4 · Tel: (506) 276-4567 · Fax: (506) 276-4380 · sales@bwstrailers.com

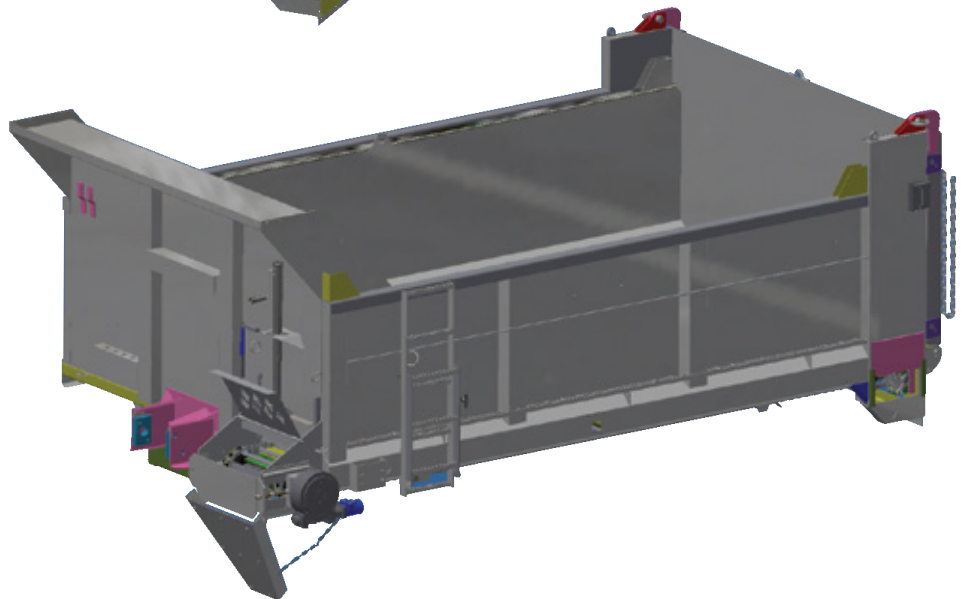
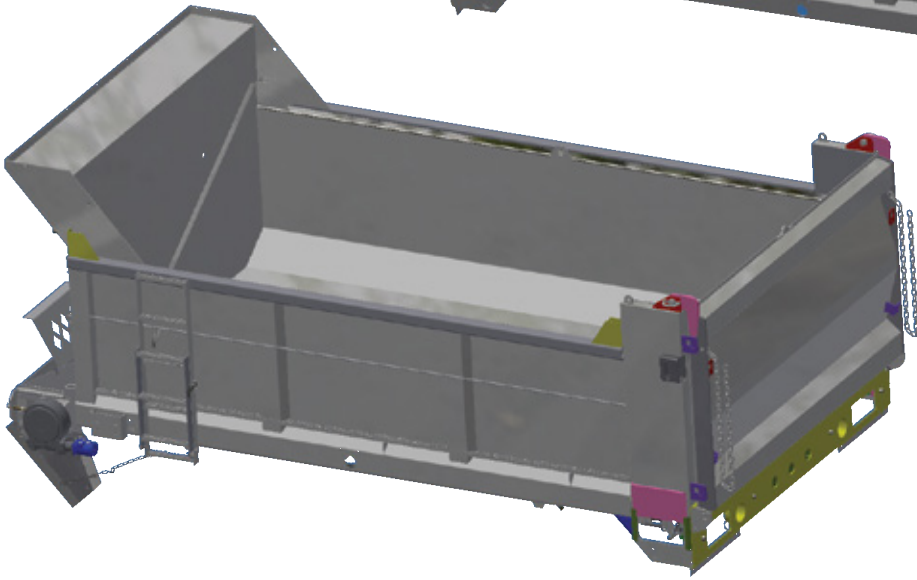
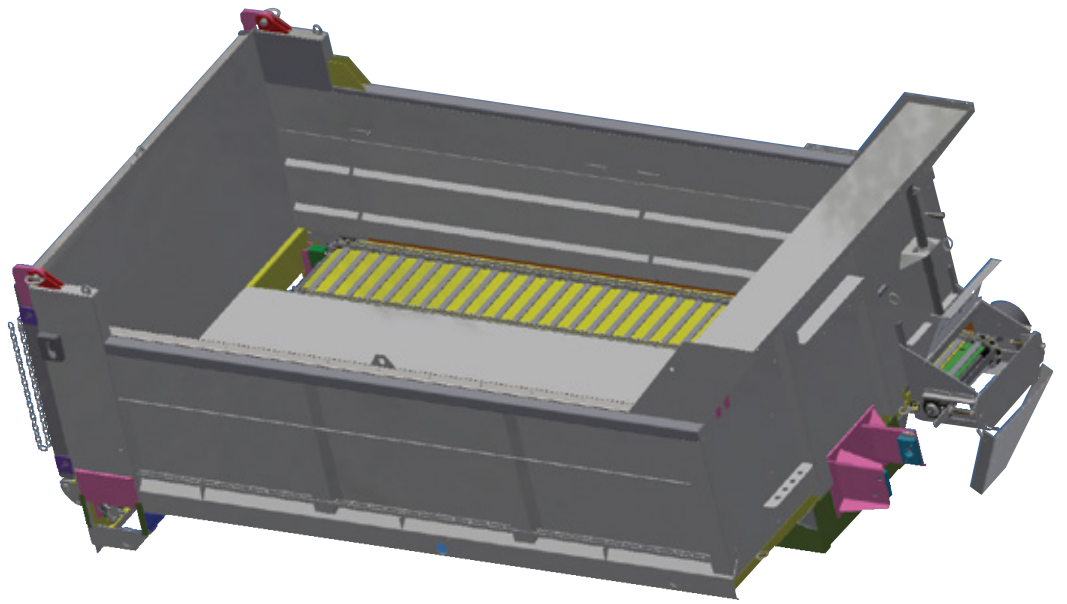

Authorised BWS Dealer