

BWS P/N:9100079 REV: 4



LAND PRO

OPERATOR'S MANUAL

LANDPRO
DECEMBER 2018

www.bwstrailers.com
toll free 888.896.5777



ISO 9001:2015
CERTIFIED

INTRODUCTION

The BWS product you have just taken delivery of has been carefully designed and built for easy, low maintenance, reliable operation that meets the requirements of a shrewd transportation industry.

We take this opportunity to thank you for choosing BWS Manufacturing Ltd, and your interest in continued safety and reliable operation of this equipment through its' dealer and service network abroad. BWS trailers require that you and anyone else who will be operating or maintaining the trailer, read this manual carefully and understand the Safety, Operation, Maintenance and Trouble Shooting information contained in the Operator's Manual.

PRODUCTS

FORESTRY

- Logging trailers, straight and drop frames
- Hydraulic & air detachable goosenecks
- B-Train loggers
- Jeeps
- Tag-a-longs

GENERAL FREIGHT

- Equipment trailers
- Hydraulic & Air Detachable Goosenecks
- Highway Drop Decks
- Highway Flatbeds
- B-Train Flatbeds
- Pony Trailer

CONSTRUCTION

- Low bed equipment trailers
- Detachable & fixed goosenecks
- Hydraulic & air detachable goosenecks
- Tag-a-long trailers, tilting & non-tilting decks
- Dump trailers
- Jeeps
- Boosters
- Live Bottom trailers

HYDRO/TELEPHONE

- Cable Reel trailers

SPECIAL ORDER TRAILERS

- Nuclear Waste
- Generator Trailers
- Wagon Type Trailers
- Military Trailers
- Specialty Trailers for offshore products

OIL & GAS

- Oilfield trailers
- Equipment trailers
- Oilfield jeeps / Oilfield hydraulics
- Hydraulic goosenecks
- Scissorsnecks
- Tag-a-longs

PAVING & RECOVERY

- Aggregate Screeners
- Hydraulic & air detachable goosenecks
- Equipment trailers
- Tag-a-longs
- Dump Trailer
- Live Bottom trailers

SNOW & ICE

- A/S Dump Sanders
- A/S U-Body Dump Sanders

BWS COMPANY HISTORY

BWS Trailers are engineered, designed and manufactured in Centreville, New Brunswick. It is a family owned and managed business that is dedicated and committed to delivering outstanding value. Our success is built on thinking like the customer and producing trailers that can be relied on year after year without fail.

Since 1967, we have gained and maintained the trust and respect of experienced customers who work in the oil fields, construction, equipment and machinery moving, forestry, road building, paving and private contracting industries.

Originally BWS manufactured custom trailers with a focus on forestry and agriculture. Having built a solid reputation in this rough off-road industry and operating in the tough Canadian environment, BWS continues today to manufacture trailers that are designed to meet the customers' expectations in the environments in which they operate. The units are designed to go to work and stay at work.

BWS has expanded its product line into areas where it can continue to provide high quality solutions that deliver value.

The employees of BWS are a dedicated workforce with a "craftsman" mentality. Many of its senior people have past experience operating trailers and equipment and this has resulted in their philosophy of putting themselves in the shoes of their customers. BWS relies heavily on feedback from both their dealers and their customers. They build what performs, not just what sells and that is what has contributed to their significant growth throughout North America over the last several years.

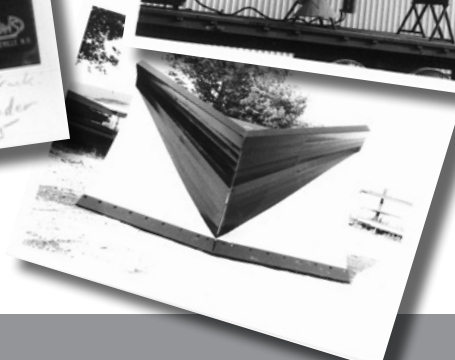



**CERTIFIED
CSA W47.1**



QUALITY POLICY

BWS Manufacturing is totally committed to understanding and meeting the quality needs and expectations of all our customers. Our company has a proud reputation for delivering quality equipment and components.

BWS strives for continuous improvement of our product and meeting the objectives of the company. We are also committed to the continuous improvement of our quality management system to insure its suitability to meet all company, customer, regulatory, legal and ISO requirements.

The entire BWS team will adhere to the spirit and intent of our quality policy, as well as the directives of this quality assurance manual and its supporting quality system documentation. We will continue to aggressively strive to insure that customer satisfaction is achieved at all times, and in all things.



Hugo St-Cyr
CEO



LANDPRO ASSEMBLY INSTRUCTIONS

ASSEMBLY INSTRUCTION

TOOLS REQUIRED:

OVERHEAD CRANE AND RIGGING

TORQUE WRENCH 700 FT LBS

REQUIRED TORQUE VALUES ARE ON PAGES 3-8 ASSEMBLY DRAWINGS

1 ½" SOCKET

1 ½" WRENCH

15/16" WRENCH

7/8" WRENCH

3/4" WRENCH

9/16" WRENCH

1/2" WRENCH

7/16" WRENCH

WISE GRIPS

2 LB HAMMER

SMALL AND MEDIUM LINE UP PUNCH

LP 14 - 16 - 18 HYDRAULIC SCHEMATIC

25100100

ITEM	DESCRIPTION	PART NUMBER	QTY
1	BLADE CYLINDERS	91000026	2
2	AXLE CYLINDERS	91000027	2
3	1/2 NPT ALL FEMALE TEE	9331	4
4	AG-MALE QUICK CONNECT	9809	4
5	250" HOSE BLADE CYLINDERS	25100106	2
6	64" 1" HOSE BLADE CYLINDER	25100109	2
7	54" 1" HOSE AXLE/BLADE	25100108	6
8	M-ORB TO FM NPT 90 DEG 08-J08	9818	8
9	24" POLLY SLEEVE	91000022	5
10	264" NYLON SLEEVE	91000023	2
11	DOUBLE HOSE CLAMP	91000024	8
12	294" HOSE TILT CYLINDERS	25100124	2

FOR PD 16 BLADE AND AXLE CYLINDERS SEE DRAWING P/N 25100001.

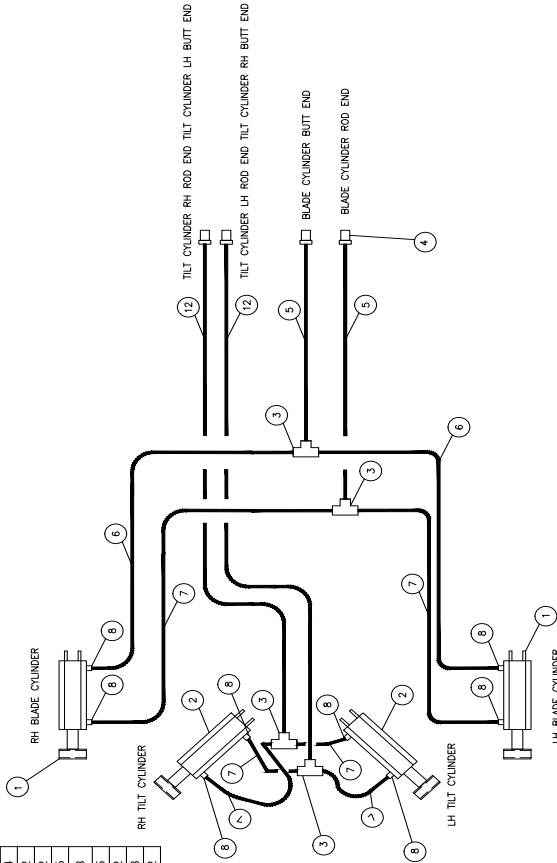

REV 3	LAO	7/29/2015	CYLINDERS CHANGED TO 4" BORE X 2" SHAFT.
REV 2	LAO	7/22/2014	FITTING ORBIT WAS ADDED
TOLERANCES: S/W ± 1/16 SHER ± 1/16 IRONWORKER ± 1/16 BRAKE ± 1"			
LATH ± .005 MILLING ± .005 UNW DRILL ± .005			
BMS Manufacturing Ltd.		P.O. BOX 429	
		CANTON, IL 61515	
		CHINA	
L. ORSER		DATE	7/19/2013
		DRAWN	NIS
		SCALE	1
		MODEL	PD-16-18
		WORK. No.	25100100
TITLE HYDRAULIC SCHEMATIC			

ELECTRICAL SCHEMATIC

WS043

REV. 1

MACHINE SHOP:

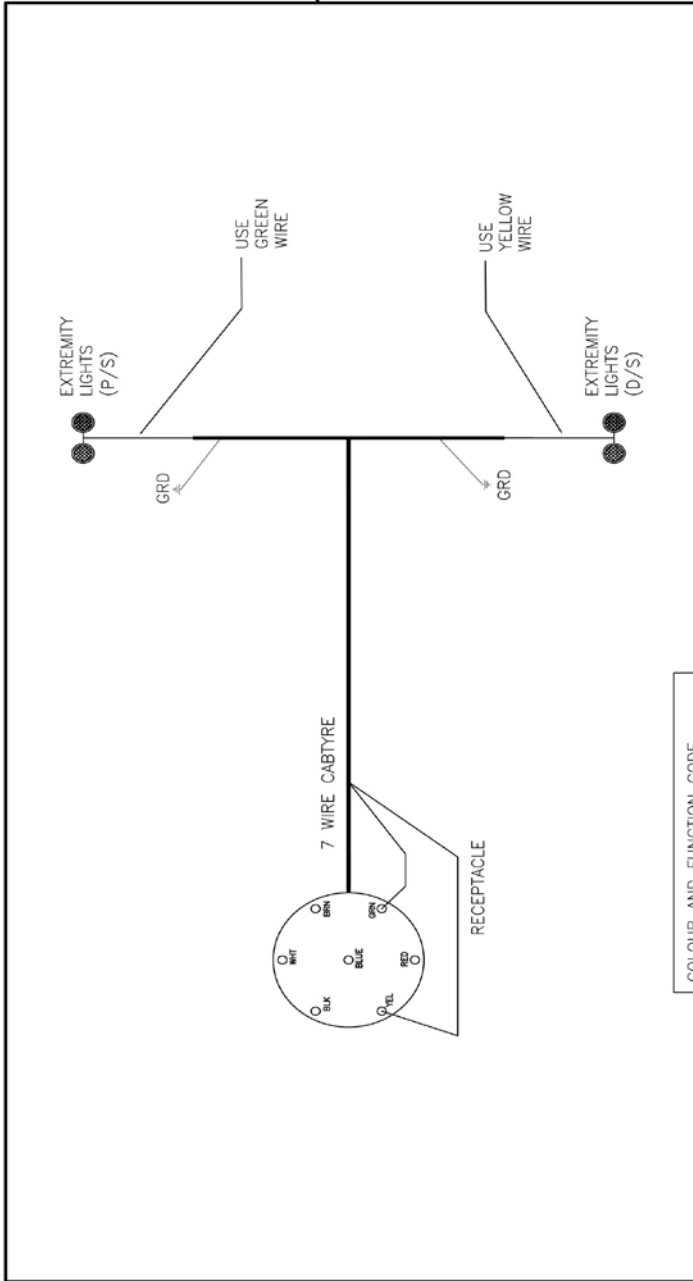

REV.	BY	DATE	DESCRIPTION	UNIT	SCALE	SHT	MODEL	DWG. No.	REV	UNITS
1	FBC	2016/06/16	ADDED NOTES							
0	SWRS	2015/08/10	INITIAL ISSUE - MODIFIED FROM WS039.	LAND MASTER / LAND PRO						
<p>BWS Manufacturing Ltd. 10 MONTANA ST. CANADA T5K 3E9 PH: (506) 276-4567 FAX: (506) 276-4380</p>										
<p>Electrical Schematic TITLE: ELECTRICAL SCHEMATIC SHT: 1 OF 1 MODEL: LM DWG. No.: WS043</p>										

COLOUR AND FUNCTION CODE	
WHITE	GROUND (GRD)
BROWN	MARKER LIGHTS
GREEN	RH SIGNAL
RED	STOP
YELLOW	LH SIGNAL
BLACK	MARKER LIGHTS
BLUE	ABS



TR:

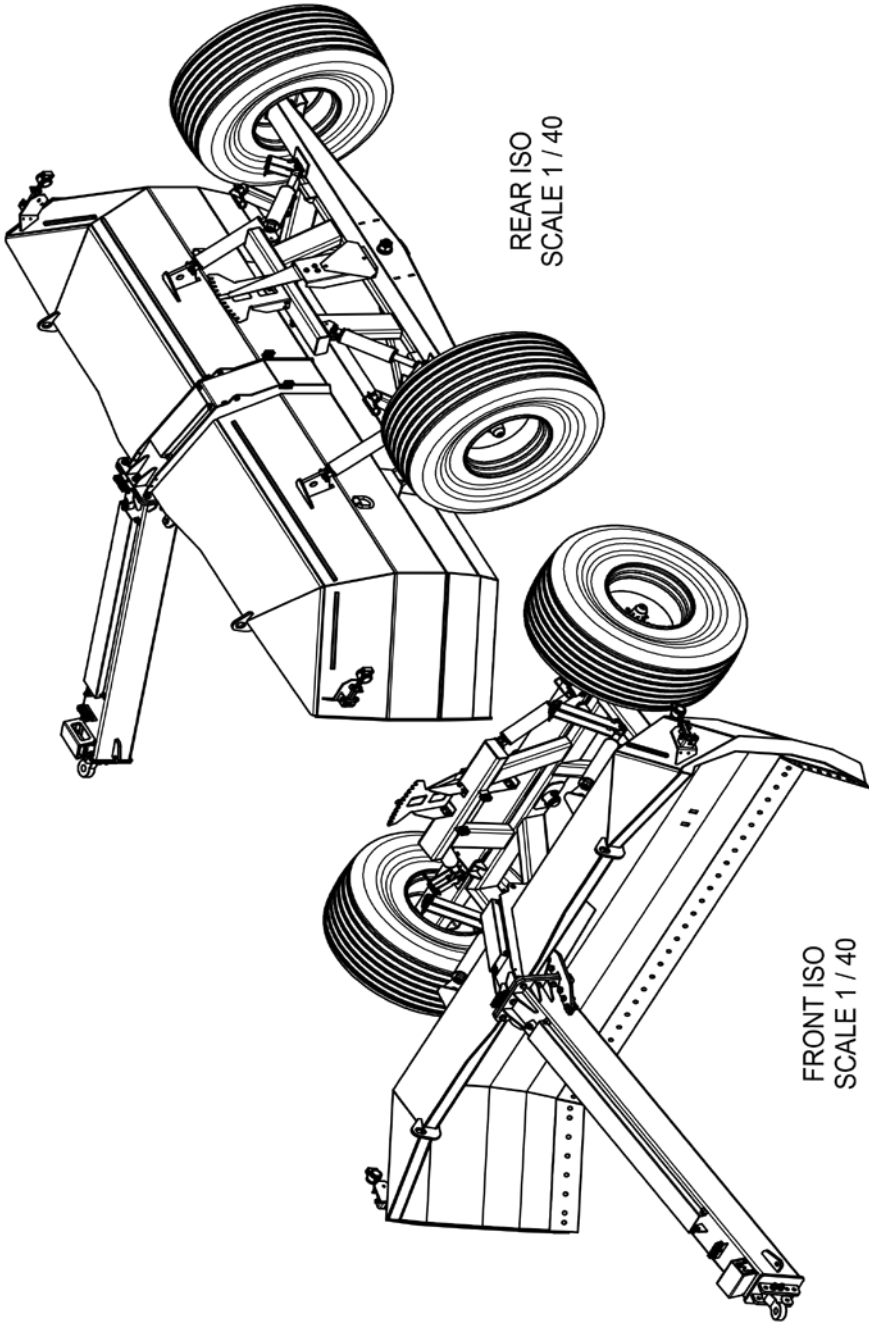

REAR ISO
SCALE 1 / 40

FRONT ISO
SCALE 1 / 40

LAND PRO 18 FT.

NOTE: ALL DIMENSIONS ARE NOMINAL. VERTICAL DIMENSIONS ARE SHOWN UNLOADED.

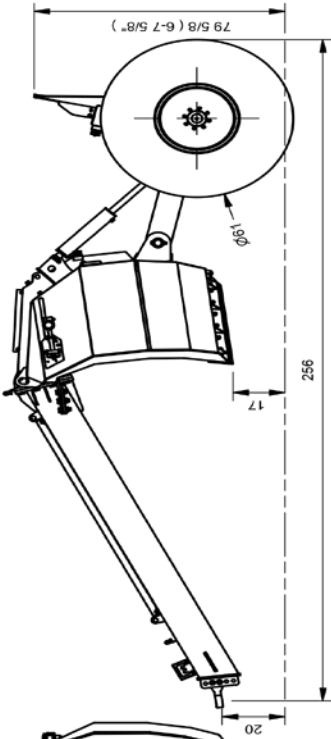

TRANSPORT POSITION
SCALE 1 / 50

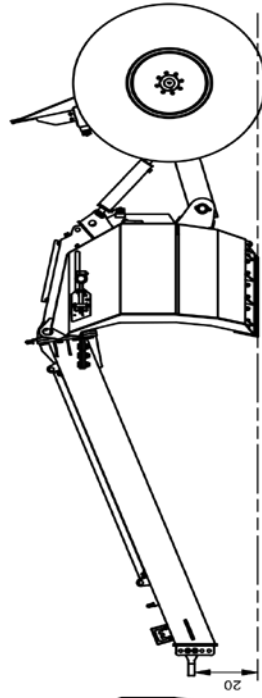
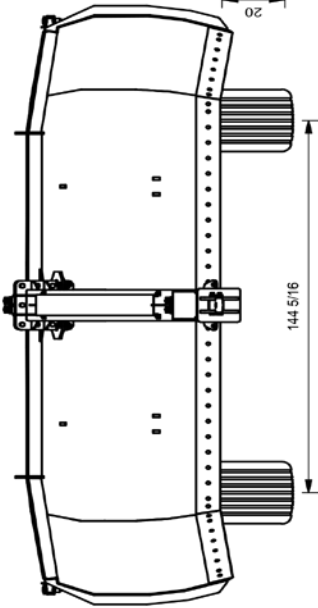

LOAD POSITION
SCALE 1 / 50

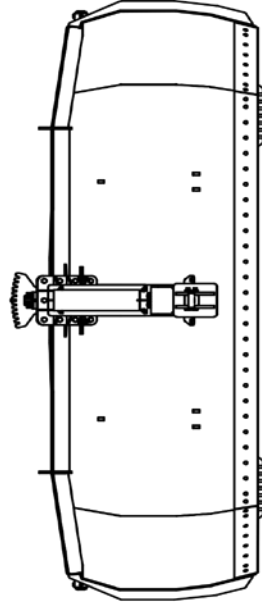

LAND PRO 18 FT.

NOTE: ALL DIMENSIONS ARE NOMINAL. VERTICAL DIMENSIONS ARE SHOWN UNLOADED.

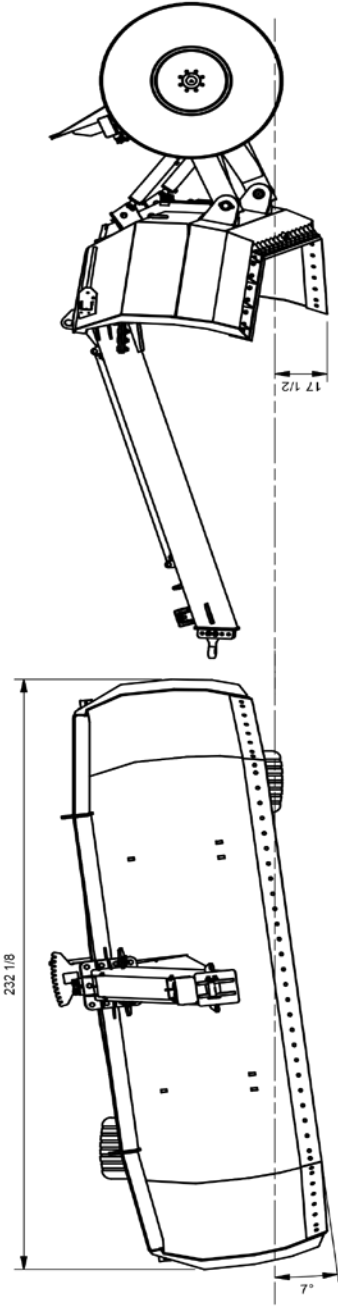

TILT POSITION (LEFT OR RIGHT) FRONT
SCALE 1 / 50

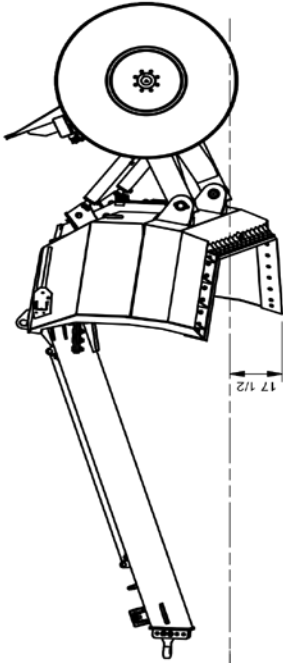

TILT POSITION (LEFT OR RIGHT) WORKING POSITION
SCALE 1 / 50

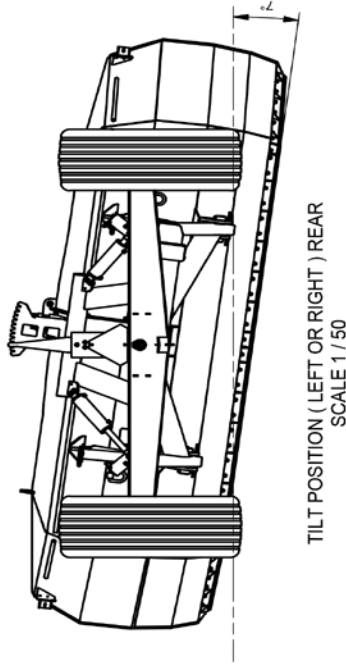

TILT POSITION (LEFT OR RIGHT) REAR
SCALE 1 / 50

LAND PRO 18 FT.

NOTE: ALL DIMENSIONS ARE NOMINAL. VERTICAL DIMENSIONS ARE SHOWN UNLOADED.

LP14 MAIN ASSEMBLY

25100226 REV. 5

1/2

MAIN ASSEMBLY

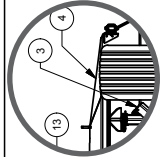
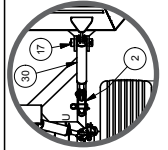
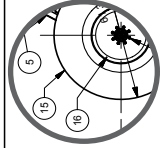
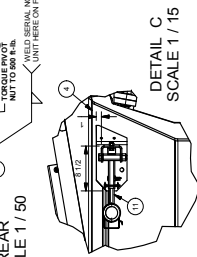
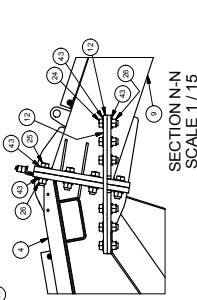
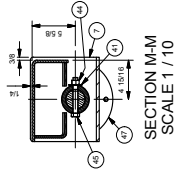
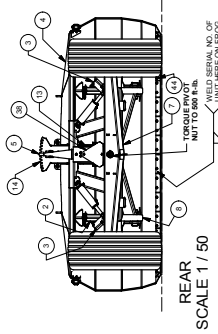
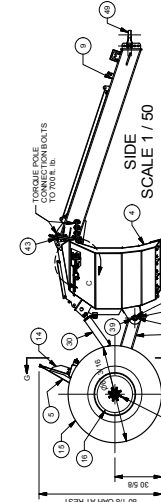
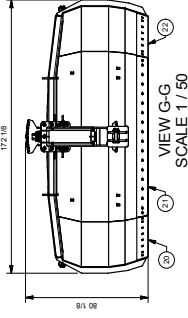
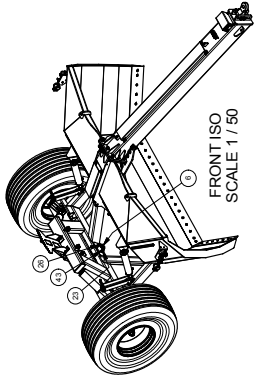
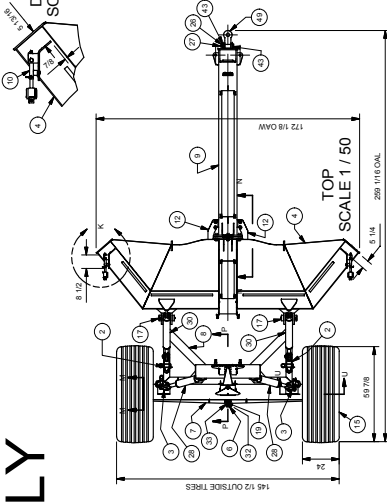
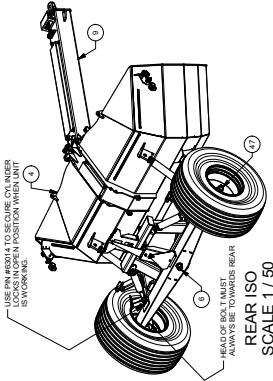

1	1/50	12/24/2017	REVISIONS TO L14 2017 14 FT. LAND PRO MAIN ASSEMBLY
2	1/50	10/27/17	REVISIONS TO L14 2017 14 FT. LAND PRO MAIN ASSEMBLY
3	1/50	09/07/17	REVISIONS TO L14 2017 14 FT. LAND PRO MAIN ASSEMBLY
4	1/50	06/20/17	ADJUST WHEELS TO CONNECTION BRACKET TO UNIT
5	1/50	02/20/15	INITIAL ISSUE
REV BY	DATE	DESCRIPTION	DRVD
TOLERANCES:	DIMENSIONS IN THIS DRAWING UNLESS OTHERWISE SPECIFIED		
	SIZE IN LARGEST DIMENSION UNLESS OTHERWISE SPECIFIED		
	TOLERANCES:		
	DRAWN BY	MARKER BY	INCHES: 1/16
	LAINE E. JOOS	MILLING: E. JOOS	MILLING: E. JOOS
	14 FT. LAND PRO MAIN ASSEMBLY		
	UNIT		
	TITLE		
	MANUFACTURER		
	DATE	SCALE	REV
	11/15/2015	1:1	1 OF 2
	AS NOTED		P014
	DRAWN BY		REV
	LAINE E. JOOS		25100226
	SCALE		5
	AS NOTED		UNIT
TR:			MACH. SHOP: - - - -

LP16 MAIN ASSEMBLY

25100001 REV. 4

1/2

MAIN ASSEMBLY

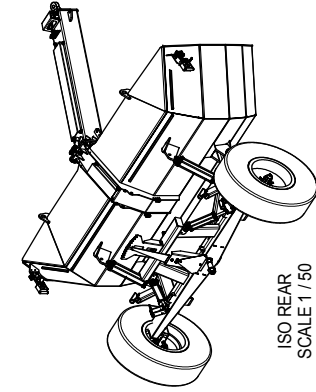

ISO REAR
SCALE 1 / 50

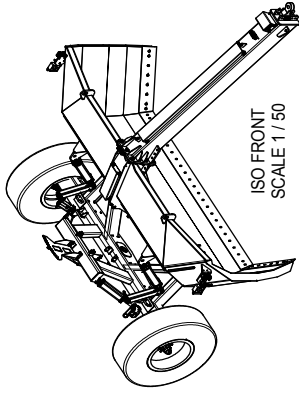
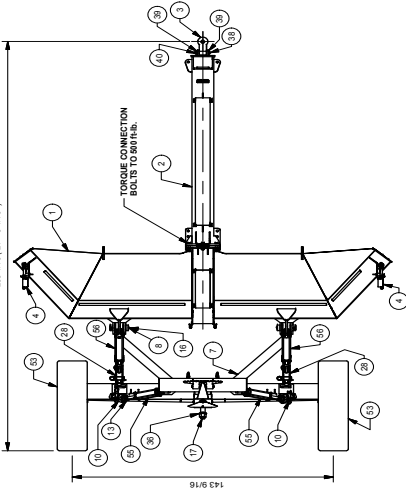

ISO FRONT
SCALE 1 / 50

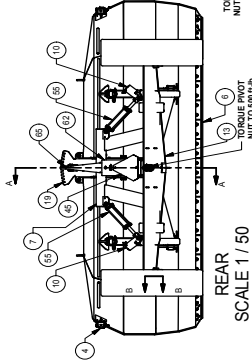

REAR
SCALE 1 / 50

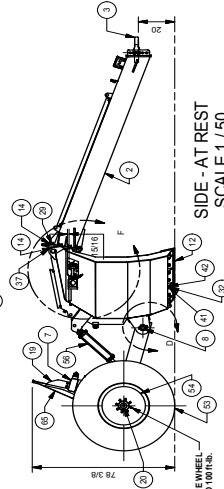

SIDE - AT REST
SCALE 1 / 50

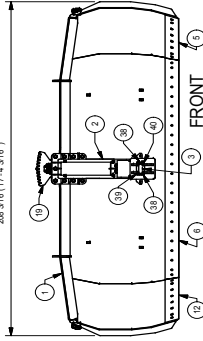

FRONT
SCALE 1 / 50

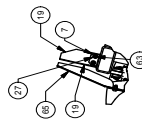

DETAIL E
SCALE 1 / 25

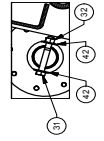

SECTION B-B
SCALE 1 / 10

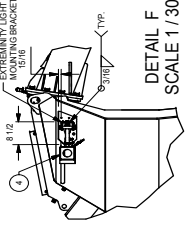

DETAIL F
SCALE 1 / 30

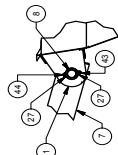

DETAIL D
SCALE 1 / 25

4	FEC	18/2014	ADDED NOTE SERIAL NO. IS TO BE WELDED ON PROS
3	FEC	8/19/2013	UPDATED TO SHOW DESIGN CHANGES
2	FEC	3/23/2013	REVISED TO SHOW DESIGN CHANGES
1	FEC	1/28/2013	ISSUED ASSESS
51	REV		DATE
WELDING			
PROCEDURES AS PER APPROVED COMP-PROCESSES ONLY			
SIZES AND 1000 POUNDS THREE EIGHTS CARRIER THICKNESS 4 * 1/4"			
TOLERANCES			
FINISHES FINISHES TO PART NUMBER 1/16			
LATEL F. 005			
MILKING L. 005			
DRLK L. 005			
BRACKET 1"			
LIMIT			
LAND/MADE - 16 FT. ASSEMBLY			
TITLE			
MAIN ASSEMBLY			
DRAWN BY	DATE	SCALE	REV
FBC	7/26/2013	AS NOTED	1, #2, PD 16, 25.0/001, 4
MACH. SHOP:			LIMITS
TR.			

STANDARD				LASER			
ITEM QTY	STOCK No.	PART No.	DESCRIPTION	LENGTH	WIDTH	AREA (SQ.FT.)	COMMENTS
21	9100009	2510003	LAND BLADE - 16 FT BLADE ASSEMBLY	201000.00	.00	201000.00	ASSY
2	9100004	2510004	HITCH POLE ASSEMBLY	910000.00	.00	910000.00	ASSEMBLY
3	9100009	2510009	BIPOLA	910000.00	.00	910000.00	STOCK
4	9100009	2510009	EXTREMELY LIGHT SWING OUT	201000.00	.00	201000.00	ASSY
1	9100010	2510005	8 X 8 DOUBLE BEVEL	201000.00	.00	201000.00	STOCK
1	9100010	2510006	8 X 8 DOUBLE BEVEL	201000.00	.00	201000.00	STOCK
1	9100010	2510007	8 X 8 DOUBLE BEVEL	201000.00	.00	201000.00	STOCK
7	9100010	2510008	LAND BLADE PIVOT ARM ASSEMBLY	201000.00	.00	201000.00	ASSEMBLY
8	9100010	2510009	BAR 2 1/2 DIA. STRESSPOOF	201000.00	.00	201000.00	STD. SAW DRILL MACH.
10	2	48012	2510009	BAR 2 1/2 DIA. STRESSPOOF	201000.00	.00	ASSY
10	2	48012	2510009	BAR 2 1/2 DIA. STRESSPOOF	201000.00	.00	ASSY
12	1	9100010	2510003	8 X 8 - DOUBLE BEVEL	201000.00	.00	STD. STOCK TORCH
13	1	9100010	2510003	8 X 8 - DOUBLE BEVEL	201000.00	.00	STD. STOCK TORCH
13	1	9100010	2510003	8 X 8 - DOUBLE BEVEL	201000.00	.00	STD. STOCK TORCH
14	22	401248	03271	Flat Washer 1/2x2x.015	2010151.00	.00	ASSY
16	3	98005	1/8 NPT 81 28 Rk	2010152.00	.00	2010152.00	STOCK
17	1	48012	2510015	BAR 2 1/2 STRESSPOOF	2010152.00	.00	STOCK
20	2	17907	9100008	HUBEND ASSY #HDAR12.5012.005	2010152.00	.00	STD. SAW DRILL MACH.
24	2	17907	2510017	UNION PCK 2.58	2010171.00	.00	STOCK
25	18	401248	03282	Flat Washer 1/2x2x.015	2010171.00	.00	ASSY
26	18	401248	03282	Flat Washer 1/2x2x.015	2010171.00	.00	ASSY
26	2	1000074	25100074	CYLINDER STOP - LARGE	2010074.00	.00	STOCK
30	1	03105	03105	Bolt Hex 1/8 UNC - 3.5	2010074.00	.00	STOCK
31	2	03063	03063	Bolt Hex 3/8 X 1/2 GR 8	03063.00	.00	STOCK
32	4	401248	01094	Nut Hex 5/8 - 11 UNC	2010122.00	.00	STOCK
36	1	401248	25100122	FIBER WASHER 4" OD X 2 1/2 ID X .188	03719.00	.00	STOCK
37	1	03148	03148	Bolt Hex 1" UNC x 1/2 GR 8	03719.00	.00	STOCK
38	2	03276	03276	Bolt Hex 1" UNC x 1/2 GR 8	03276.00	.00	STOCK
39	4	401248	01079	WASHER FLAT 1" SAE (GR 8)	03248.00	.00	STOCK
40	2	1000074	25100074	CYLINDER STOP - LARGE	03248.00	.00	STOCK
41	14	401248	01026	Bolt 1" CON. HEAD 3/8 X 2	03248.00	.00	STOCK
42	1	03282	03282	Flat Washer 1/2x2x.015	03248.00	.00	STOCK
43	1	03282	03282	Flat Washer 1/2x2x.015	03248.00	.00	STOCK
44	2	1000074	25100074	CYLINDER STOP - LARGE	03248.00	.00	STOCK
45	1	03112	03112	Bolt Hex 1/2 X 1/2 UNC - 4.5	2010077.00	.00	STOCK
46	1	1000077	1" SLO-MOVING MECH. SEAL	16.378 in	14 in	16.378 in	157
47	2	03002	03002	Bolt Hex 1/4-20 UNC - 0.75	2010077.00	.00	STOCK
48	4	03265	03265	Flat Washer 1/2x1.5x.015	2010077.00	.00	STOCK
49	2	1000003	9100003	18 X 4 X 20 10R VASO201	03750.00	.00	STOCK
50	2	1000004	9100004	WHEEL 18 X 4 X 20 10R VASO201	03750.00	.00	STOCK
51	2	1000004	9100004	WHEEL 18 X 4 X 20 10R VASO201	03750.00	.00	STOCK
52	2	1000004	9100004	WHEEL 18 X 4 X 20 10R VASO201	03750.00	.00	STOCK
53	2	1000004	9100004	WHEEL 18 X 4 X 20 10R VASO201	03750.00	.00	STOCK
54	2	1000004	9100004	WHEEL 18 X 4 X 20 10R VASO201	03750.00	.00	STOCK
55	2	1000004	9100004	WHEEL 18 X 4 X 20 10R VASO201	03750.00	.00	STOCK
56	2	1000004	9100004	WHEEL 18 X 4 X 20 10R VASO201	03750.00	.00	STOCK
57	1	1000004	9100004	WHEEL 18 X 4 X 20 10R VASO201	03750.00	.00	STOCK
58	1	1000004	9100004	WHEEL 18 X 4 X 20 10R VASO201	03750.00	.00	STOCK
59	1	1000004	9100004	WHEEL 18 X 4 X 20 10R VASO201	03750.00	.00	STOCK
60	1	1000004	9100004	WHEEL 18 X 4 X 20 10R VASO201	03750.00	.00	STOCK
61	1	1000004	9100004	WHEEL 18 X 4 X 20 10R VASO201	03750.00	.00	STOCK
62	1	1000004	9100004	WHEEL 18 X 4 X 20 10R VASO201	03750.00	.00	STOCK
63	1	1000004	9100004	WHEEL 18 X 4 X 20 10R VASO201	03750.00	.00	STOCK
64	1	1000004	9100004	WHEEL 18 X 4 X 20 10R VASO201	03750.00	.00	STOCK
65	1	1000004	9100004	WHEEL 18 X 4 X 20 10R VASO201	03750.00	.00	STOCK

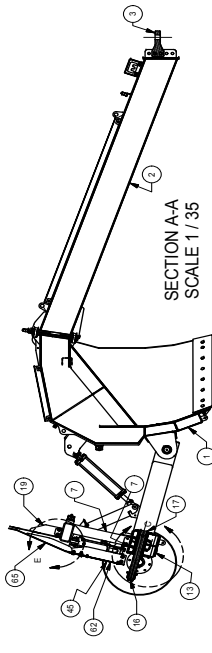
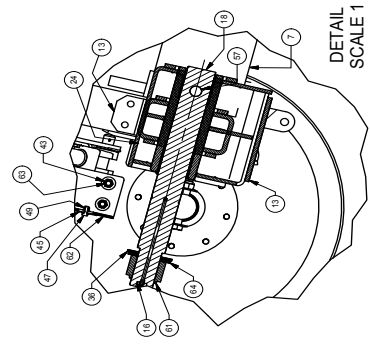

4	REC	10/2013	UPDATED ASSEMBLY TO SHOW DESIGN CHANGES
3	REC	9/16/2013	UPDATED TO SHOW DESIGN CHANGES
2	REC	8/30/2013	REVISED TO SHOW DESIGN CHANGES
1	REC	8/29/2013	ISSUE
52	DRG	DATE	ISSUE
53	DRG	DATE	ISSUE
REVISIONS: PROCEDURE AS PER APPROVED P&ID PROCESSES ONLY			
SIZES UNLESS OTHERWISE SPECIFIED ARE IN INCHES 1/16			
TOLERANCES: LATHE .0005 MILLING .0005 DRILL .005			
UNIT			
LAND BLADE - 16 FT. MAIN ASSEMBLY			
TITLE			
DRAWN BY: [Name]			
CHECKED BY: [Name]			
APPROVED BY: [Name]			
DATE: 7/26/2013			
SCALE: 2:42			
MACH. SHOP: [Name]			
PARTS LIST			
REV: 2010001			
DWG. NO. [Name]			
MFG. NO. [Name]			

PART LIST		PART LIST					
ITEM	QTY	STOCK NO.	DESCRIPTION	LENGTH	WIDTH	AREA (SQ.FT.)	COMMENTS
37	3	00955	1/8 NF1 ST ZAK				
38	12	03288	ANSI SAE B18.1 - 1/8 UNC - 3/2"				STOCK
39	12	03288	SOFT HX 1/8 UNC x 3/2 GR 8				STOCK
40	2	0260	Plain Lockwasher 1"				STOCK
41	2	0458	SOFT HX 1/8 UNC X 3/2 GR 8				STOCK
42	2	0458	SOFT HX 1/8 UNC X 3/2 GR 8				STOCK
43	2	0458	SOFT HX 1/8 UNC X 3/2 GR 8				STOCK
44	4	03289	PLAIN LOCK WASHER 0.825				STOCK
45	4	03289	PLAIN LOCK WASHER 0.825				STOCK
46	4	03289	PLAIN LOCK WASHER 0.825				STOCK
47	4	03289	PLAIN LOCK WASHER 0.825				STOCK
48	4	03289	PLAIN LOCK WASHER 0.825				STOCK
49	4	03289	PLAIN LOCK WASHER 0.825				STOCK
50	2	03112	SOFT HX 1/2-13 UNC - X 2"				STOCK

PART LIST		PART LIST					
ITEM	QTY	STOCK NO.	DESCRIPTION	LENGTH	WIDTH	AREA (SQ.FT.)	COMMENTS
1	1	2510002	LAND BLADE - BLADE ASSEMBLY				ASSY
2	2	2510192	CYLINDER STOP - SHORT				ASSY
3	2	2510191	CYLINDER STOP - LONG				ASSY
4	1	2510041	HITCH PALE ASSEMBLY				ASSEMBLY
5	1	2510041	HITCH PALE ASSEMBLY				ASSEMBLY
6	1	2510041	HITCH PALE ASSEMBLY				ASSEMBLY
7	1	2510041	HITCH PALE ASSEMBLY				ASSEMBLY
8	1	2510041	HITCH PALE ASSEMBLY				ASSEMBLY
9	1	2510041	HITCH PALE ASSEMBLY				ASSEMBLY
10	1	2510041	HITCH PALE ASSEMBLY				ASSEMBLY
11	1	2510041	HITCH PALE ASSEMBLY				ASSEMBLY
12	1	2510041	HITCH PALE ASSEMBLY				ASSEMBLY
13	1	2510041	HITCH PALE ASSEMBLY				ASSEMBLY
14	1	2510041	HITCH PALE ASSEMBLY				ASSEMBLY
15	1	2510041	HITCH PALE ASSEMBLY				ASSEMBLY
16	1	2510041	HITCH PALE ASSEMBLY				ASSEMBLY
17	1	2510041	HITCH PALE ASSEMBLY				ASSEMBLY
18	1	2510041	HITCH PALE ASSEMBLY				ASSEMBLY
19	1	2510041	HITCH PALE ASSEMBLY				ASSEMBLY
20	1	2510041	HITCH PALE ASSEMBLY				ASSEMBLY
21	1	2510041	HITCH PALE ASSEMBLY				ASSEMBLY
22	1	2510041	HITCH PALE ASSEMBLY				ASSEMBLY
23	1	2510041	HITCH PALE ASSEMBLY				ASSEMBLY
24	1	2510041	HITCH PALE ASSEMBLY				ASSEMBLY
25	1	2510041	HITCH PALE ASSEMBLY				ASSEMBLY
26	1	2510041	HITCH PALE ASSEMBLY				ASSEMBLY
27	1	2510041	HITCH PALE ASSEMBLY				ASSEMBLY
28	1	2510041	HITCH PALE ASSEMBLY				ASSEMBLY
29	1	2510041	HITCH PALE ASSEMBLY				ASSEMBLY
30	1	2510041	HITCH PALE ASSEMBLY				ASSEMBLY
31	1	2510041	HITCH PALE ASSEMBLY				ASSEMBLY
32	1	2510041	HITCH PALE ASSEMBLY				ASSEMBLY
33	1	2510041	HITCH PALE ASSEMBLY				ASSEMBLY
34	1	2510041	HITCH PALE ASSEMBLY				ASSEMBLY
35	1	2510041	HITCH PALE ASSEMBLY				ASSEMBLY
36	1	2510041	HITCH PALE ASSEMBLY				ASSEMBLY
37	1	2510041	HITCH PALE ASSEMBLY				ASSEMBLY
38	1	2510041	HITCH PALE ASSEMBLY				ASSEMBLY
39	1	2510041	HITCH PALE ASSEMBLY				ASSEMBLY
40	1	2510041	HITCH PALE ASSEMBLY				ASSEMBLY
41	1	2510041	HITCH PALE ASSEMBLY				ASSEMBLY
42	1	2510041	HITCH PALE ASSEMBLY				ASSEMBLY
43	1	2510041	HITCH PALE ASSEMBLY				ASSEMBLY
44	1	2510041	HITCH PALE ASSEMBLY				ASSEMBLY
45	1	2510041	HITCH PALE ASSEMBLY				ASSEMBLY
46	1	2510041	HITCH PALE ASSEMBLY				ASSEMBLY
47	1	2510041	HITCH PALE ASSEMBLY				ASSEMBLY
48	1	2510041	HITCH PALE ASSEMBLY				ASSEMBLY
49	1	2510041	HITCH PALE ASSEMBLY				ASSEMBLY
50	1	2510041	HITCH PALE ASSEMBLY				ASSEMBLY

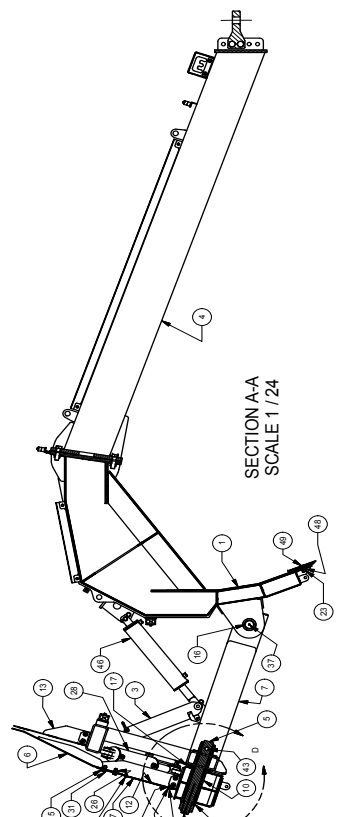
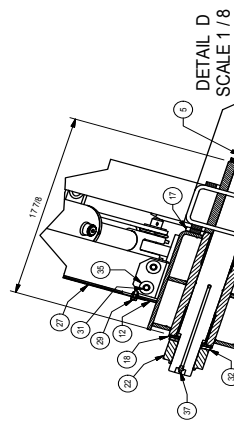

ITEM	QTY	STOCK NO.	DESCRIPTION	LENGTH	WIDTH	AREA (SQ.FT.)	COMMENTS
14	REC	3050071	REC ABENT L UNC ASSEMBLY WITH 4 L UNC FASTENERS				
15	REC	4202016	CONV ANCHOR 1 1/4" DIA X 1 1/2" L				
16	REC	4202016	CONV ANCHOR 1 1/4" DIA X 1 1/2" L				
17	REC	5302016	REC ANCHOR 1 1/4" DIA X 1 1/2" L				
18	REC	5302016	REC ANCHOR 1 1/4" DIA X 1 1/2" L				
19	REC	5302016	REC ANCHOR 1 1/4" DIA X 1 1/2" L				
20	REC	5302016	REC ANCHOR 1 1/4" DIA X 1 1/2" L				
21	REC	5302016	REC ANCHOR 1 1/4" DIA X 1 1/2" L				
22	REC	5302016	REC ANCHOR 1 1/4" DIA X 1 1/2" L				
23	REC	5302016	REC ANCHOR 1 1/4" DIA X 1 1/2" L				
24	REC	5302016	REC ANCHOR 1 1/4" DIA X 1 1/2" L				
25	REC	5302016	REC ANCHOR 1 1/4" DIA X 1 1/2" L				
26	REC	5302016	REC ANCHOR 1 1/4" DIA X 1 1/2" L				
27	REC	5302016	REC ANCHOR 1 1/4" DIA X 1 1/2" L				
28	REC	5302016	REC ANCHOR 1 1/4" DIA X 1 1/2" L				
29	REC	5302016	REC ANCHOR 1 1/4" DIA X 1 1/2" L				
30	REC	5302016	REC ANCHOR 1 1/4" DIA X 1 1/2" L				
31	REC	5302016	REC ANCHOR 1 1/4" DIA X 1 1/2" L				
32	REC	5302016	REC ANCHOR 1 1/4" DIA X 1 1/2" L				
33	REC	5302016	REC ANCHOR 1 1/4" DIA X 1 1/2" L				
34	REC	5302016	REC ANCHOR 1 1/4" DIA X 1 1/2" L				
35	REC	5302016	REC ANCHOR 1 1/4" DIA X 1 1/2" L				
36	REC	5302016	REC ANCHOR 1 1/4" DIA X 1 1/2" L				
37	REC	5302016	REC ANCHOR 1 1/4" DIA X 1 1/2" L				
38	REC	5302016	REC ANCHOR 1 1/4" DIA X 1 1/2" L				
39	REC	5302016	REC ANCHOR 1 1/4" DIA X 1 1/2" L				
40	REC	5302016	REC ANCHOR 1 1/4" DIA X 1 1/2" L				
41	REC	5302016	REC ANCHOR 1 1/4" DIA X 1 1/2" L				
42	REC	5302016	REC ANCHOR 1 1/4" DIA X 1 1/2" L				
43	REC	5302016	REC ANCHOR 1 1/4" DIA X 1 1/2" L				
44	REC	5302016	REC ANCHOR 1 1/4" DIA X 1 1/2" L				
45	REC	5302016	REC ANCHOR 1 1/4" DIA X 1 1/2" L				
46	REC	5302016	REC ANCHOR 1 1/4" DIA X 1 1/2" L				
47	REC	5302016	REC ANCHOR 1 1/4" DIA X 1 1/2" L				
48	REC	5302016	REC ANCHOR 1 1/4" DIA X 1 1/2" L				
49	REC	5302016	REC ANCHOR 1 1/4" DIA X 1 1/2" L				
50	REC	5302016	REC ANCHOR 1 1/4" DIA X 1 1/2" L				

TOLERANCES:		UNIT	
DIMENSIONS	FRACTIONS	DECIMALS	INCHES
1" & OVER	1/8"	0.005	MILLING 1.000
1/8" & UNDER	1/16"	0.001	MILLING 1.000
1/16" & UNDER	1/32"	0.0005	MILLING 1.000
1/32" & UNDER	1/64"	0.0002	MILLING 1.000
1/64" & UNDER	1/128"	0.0001	MILLING 1.000
1/128" & UNDER	1/256"	0.00005	MILLING 1.000
1/256" & UNDER	1/512"	0.00002	MILLING 1.000
1/512" & UNDER	1/1024"	0.00001	MILLING 1.000
1/1024" & UNDER	1/2048"	0.000005	MILLING 1.000
1/2048" & UNDER	1/4096"	0.000002	MILLING 1.000
1/4096" & UNDER	1/8192"	0.000001	MILLING 1.000

COMPANY	DATE	SCALE	SHEET	MODEL	DWG. No.	REV
BWS Manufacturing Ltd. <td>7/22/2013 <td>AS NOTED <td>2 <td>PDB & LPIB <td>2510000 <td></td> </td></td></td></td></td>	7/22/2013 <td>AS NOTED <td>2 <td>PDB & LPIB <td>2510000 <td></td> </td></td></td></td>	AS NOTED <td>2 <td>PDB & LPIB <td>2510000 <td></td> </td></td></td>	2 <td>PDB & LPIB <td>2510000 <td></td> </td></td>	PDB & LPIB <td>2510000 <td></td> </td>	2510000 <td></td>	
						ASSEMBLY

TITLE		MACH. SHOP:	
DATE	BY	DATE	BY

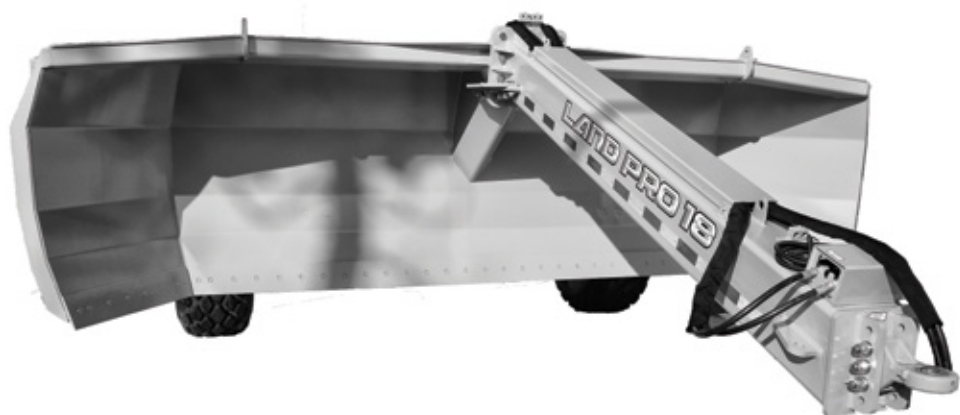



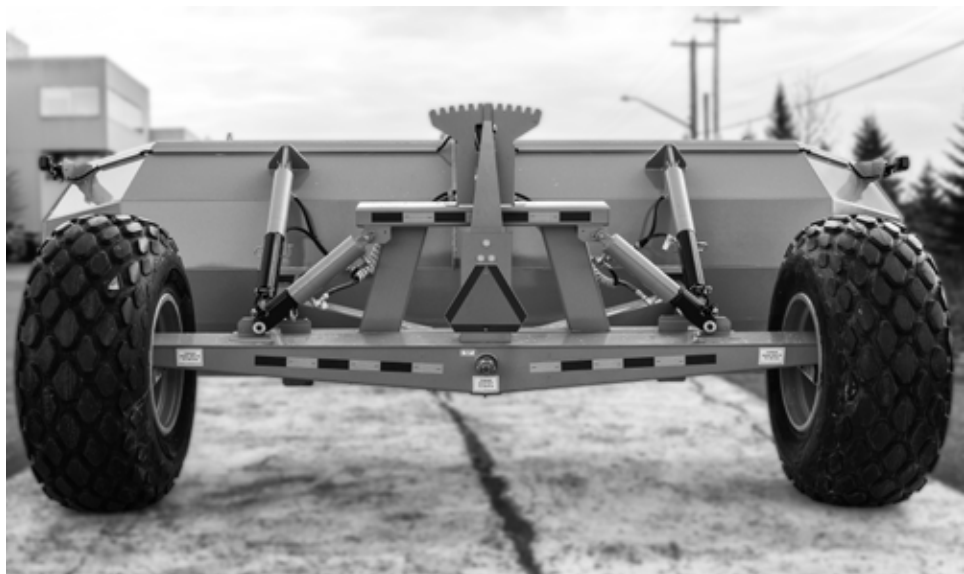



WARRANTY

FOR ASSISTANCE, PLEASE CALL SERVICE

Monday - Friday

8:00am-5:00pm AST

1-888-896-5777

1-506-276-4567

After hours email: gary.thomas@bwstrailers.com

BWS Manufacturing Ltd. - Warranty Procedures 2014

STRUCTURAL & COMPONENT WARRANTIES

Is free from defects in material and workmanship. No warranty what-so-ever on tires or ABS Sensor Alignment.

1 year 'bumper-to-bumper' - 100% Parts and Labour (from the In Service Date)

For more information, contact the nearest BWS Manufacturing Ltd. authorized dealer or visit www.bwstrailers.com

BWS CONTACT INFORMATION

29 Hawkins Road, Centreville, NB E7K 1A4

Phone (506) 276-4567

Email warranty@bwstrailers.com



LAND PRO



www.bwstrailers.com
toll free 888.896.5777



ISO 9001:2015
CERTIFIED