

H TECHNICAL PROCEDURE

TRAILER SUSPENSION SYSTEMS

SUBJECT: Shock Absorber Inspection Procedure

LIT NO: L551

DATE: December 1999 **REVISION:** A

GUIDE TO INSPECTING TRAILER SHOCKS

Like most other chassis components, a program of regular scheduled maintenance for shock absorbers will help to avoid unscheduled downtime and reduce overall maintenance costs.

The role of shocks has changed dramatically. Not so many years ago, most suspensions had heavy multi-leaf springs with limited travel and a great deal of inherent friction. These suspensions quickly self dampened and, therefore, limited the amount of work that the shock needed to perform.

Low-friction suspensions, such as air, have dramatically changed the shock's role. Shocks now play a critical role in dampening suspension oscillation.

Properly functioning shocks can help reduce the wear of more expensive suspension components, such as air bags, while assisting in the reduction of tire wear. Worn shocks simply cannot assist in providing control over today's sophisticated suspension systems.

MISTING VS. LEAKING SHOCKS

Misting shocks are often misdiagnosed as failures. Misting is the process whereby very small amounts of shock fluid evaporate at high operating temperatures through the upper seal of the shock. When the mist reaches the cooler outside air, it condenses and forms a film on the outside of the shock body. When mixed with road debris and dust, a grime will often coat the entire body of the shock. Misting is a perfectly normal and necessary function of the shock. The fluid which evaporates through the seal area helps to lubricate and prolong the life of the seal. Many technicians find it difficult to differentiate between a misting shock and a true leaker which needs to be replaced. A leaker will show clear signs of fluid leaking in streams from the upper seal. These streams can most easily be seen when the shock is fully extended and one inspects as far up the main body of the shock (underneath the dust cover or tube) as possible.

Misting - OK

Leaking - REPLACE

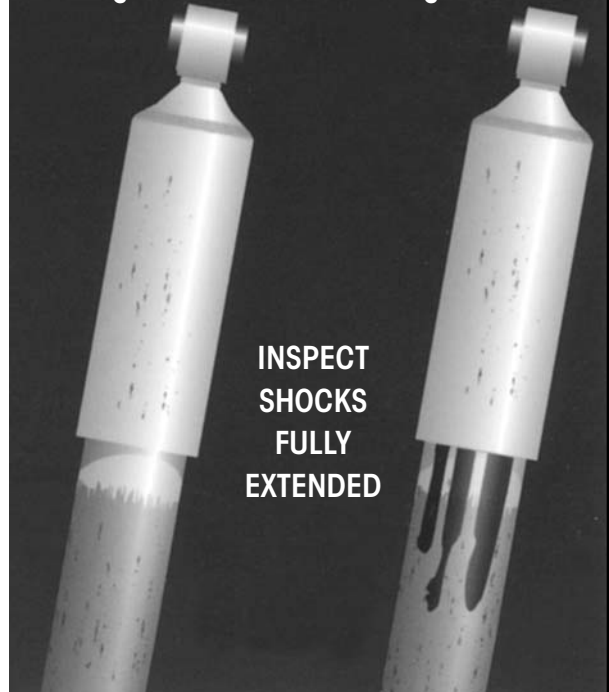

TAKE THE HEAT TEST

Shock absorbers function at temperatures ranging from ambient to 350 degrees Fahrenheit. A shock's role is to dampen the oscillation of the trailer's suspension. It does this by transforming the energy produced by the air springs to heat and dissipating it. As a result, the shock should be slightly warm to hot to the touch after normal use.

If ride deterioration is experienced and there is suspicion that a shock has failed internally, which is visually undetectable, perform the following SHOCK HEAT TEST within a few minutes of operating the equipment:

1. Pull the trailer at moderate speeds for at least fifteen minutes.
2. Within a few minutes of pulling the trailer, touch each shock absorber carefully on its body below the dust cover or tube (Figure 1), after first touching a nearby part of the frame to establish a reference ambient temperature of the metal.
3. All shock absorbers should be warmer than the frame. Suspect a failure in any shock absorber that is noticeably cooler than its mate on the other end of the axle. Different temperature on any one axle does warrant removal and examination of the cooler shock absorber.
4. To inspect for an internal failure, remove and shake the suspected shock. Listen for the sound of metal parts rattling inside. Rattling of metal parts can indicate that the shock has an internal failure.

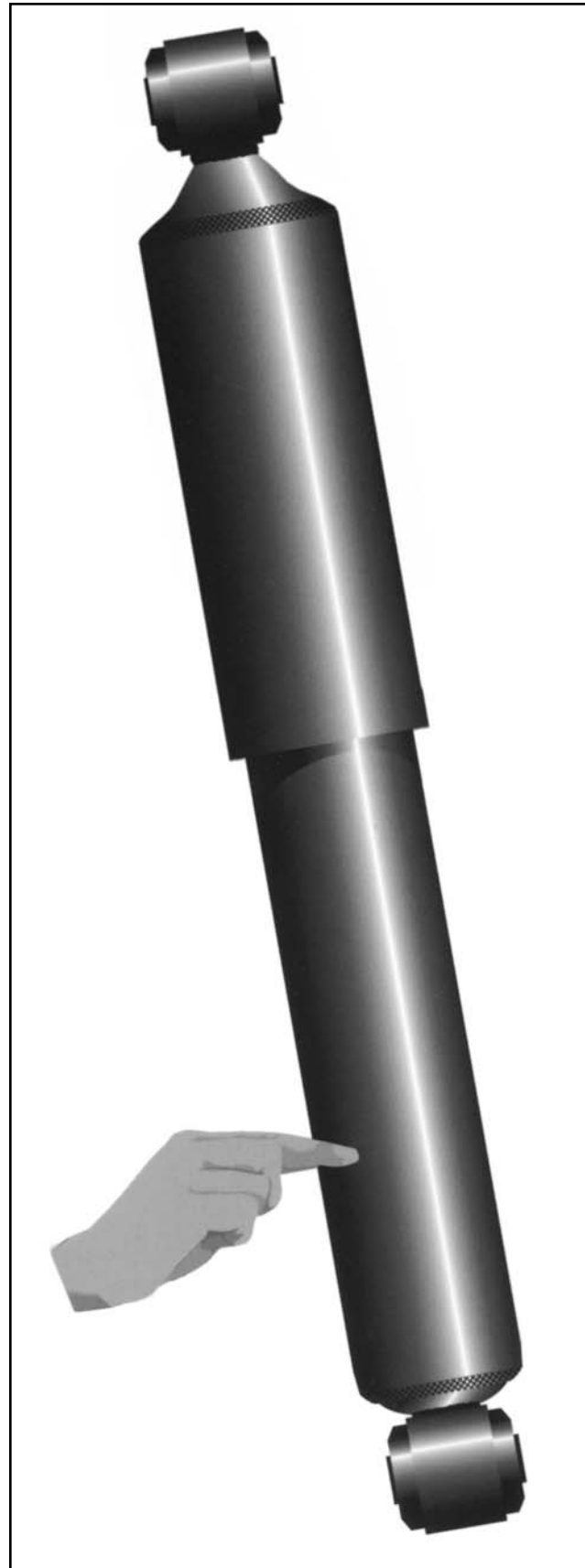

Figure 1



WHEN SHOULD SHOCKS BE REPLACED

There are many tell tale signs that indicate it may be time to replace shocks.

INSPECT FOR:

UNEVEN TIRE WEAR —
Check balance first.

RIDE DETERIORATION

BROKEN OR TORN AIR SPRINGS —
Shocks will affect air springs only if they are broken or missing.

SHOCK VISUAL CHECKS

Inspect the shocks for potential problems.

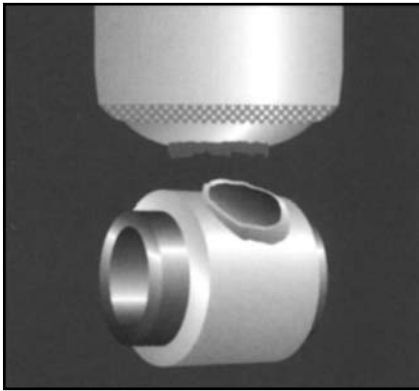

Broken upper or lower mount

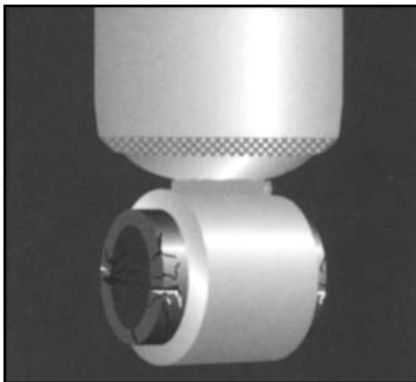

Broken upper or lower bushing
These can be replaced very easily and are considered a regular maintenance item on a shock absorber.

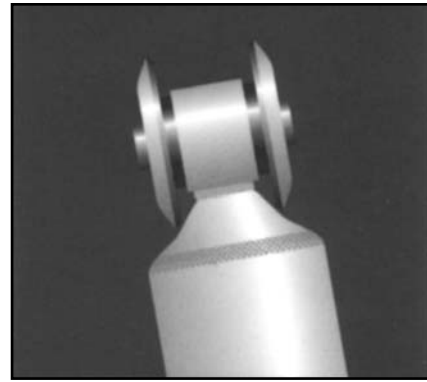

Improper installation
Example: Washer installed backwards

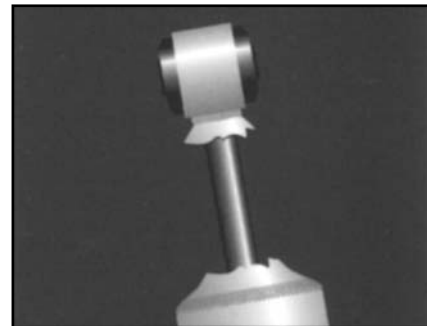

Broken dust tube

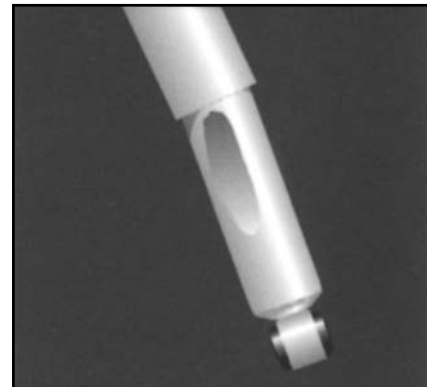

Bent or dented

www.hendrickson-intl.com



Trailer Suspension Systems
250 Chrysler Drive, Unit #3
Brampton, ON Canada L6S 6B6
905.789.1030
Fax 905.789.1033

Trailer Suspension Systems 866.RIDEAIR (743.3247)
2070 Industrial Place SE 330.489.0045
Canton, OH 44707-2641 USA Fax 800.696.4416

Trailer Suspension Systems
Av. Industria Automotriz #200
Parque Industrial Sliva Aeropuerto
Apodaca, N.L., México C.P. 66600
(52) 81 8288 1300
Fax (52) 81 8288 1301