

AXLE ADJUSTMENT PROCEDURE:

- AXLE ALIGNMENT SHALL BE IN ACCORDANCE WITH SAE OR TMC RECOMMENDED STANDARDS.
- LOOSEN 1.25 INCH NUT AT ECCENTRIC BOLT & REMOVE ANTI-TURN WASHER.
- TO MOVE AXLE: TURN ECCENTRIC BOLT HEAD IN OPPOSITE DIRECTION AXLE IS TO BE MOVED. MAXIMUM MOVEMENT FROM 12 O'CLOCK POSITION IS TO 9 OR 3 O'CLOCK POSITION. FORWARD OR REARWARD.
- WITH ECCENTRIC BOLT AT ITS FINAL SETTING, INSTALL ANTI-TURN WASHER OVER ECCENTRIC BOLT HEAD AND WELD TO BEAM. TIGHTEN 1.25 INCH NUT TO SPECIFIED TORQUE.

ITEM	SIZE	TORQUE	
		(FT-LB)	(N-M)
PIVOT (Ø1.25 FASTENERS)	1 1/4-7	1000	1356
SHOCK (Ø0.75 FASTENERS)	3/4-10	200	271
AIR SPRING (Ø0.75 FASTENERS)	3/4-16	50	68
AIR SPRING (Ø0.50 FASTENERS)	1/2-13	25	34

NOTES:

- IT IS THE INSTALLER'S RESPONSIBILITY TO TIGHTEN FASTENERS TO SPECIFIED TORQUE AFTER AXLE IS ALIGNED.
- TORQUE VALUES REFLECT LUBRICATED THREAD CONDITION (NUTS ARE PRE-LUBED).
- SUSPENSION FASTENERS TO BE RETORQUED INITIALLY AT 6,000 MILES (9,656 KM) AND 50,000 MILES (80,467 KM) INCREMENTS THEREAFTER.
- BUSHING REPLACEMENT: SEE OWNERS MANUAL FOR PROCEDURE. FOR BUSHING REPLACEMENT ORDER KIT #6040011.
- FOR AXLE TO SUSPENSION WELDING SEE RIDEWELL WELD PROCESS #1.
- SUGGESTED CROSSMEMBER LOCATION AND SIZE ARE GIVEN. SIZE AND SHAPE MAY VARY WITH THE TRAILER DESIGN AND ARE THE RESPONSIBILITY OF THE TRAILER OEM.
- STATED DOWN TRAVEL REFLECTS SUSPENSION WITH SHOCK ABSORBERS AT MAXIMUM EXTENSION AND WITH UNPRESSURIZED AIR SPRINGS. STATED UP TRAVEL REFLECTS SUSPENSION WITH AIR SPRINGS AT BUMPER CONTACT.
- STATED CAPACITY RATING FOR SUSPENSION ONLY. RATING OF AXLE, BRAKES, AND WHEEL END EQUIPMENT PER MANUFACTURER.
- INSTALLER MUST SET THE SUSPENSION TO THE SPECIFIED MOUNTING HEIGHT BEFORE TORQUING THE PIVOT BOLT TO PREVENT PRE-LOADING THE RUBBER IN THE BUSHING.
- CUTOUT IN WEB TO BE 7.06 DIA, POSITIONED AS SHOWN.
- SQUARE AND CENTER OUTER SLEEVE (ITEM 15) TO I-BEAM FLANGE CENTERLINE. WELD ALL AROUND SLEEVES BOTH SIDES. REINFORCE SLEEVE TO WEB AND FLANGES WITH CHANNELS OR GUSSETS BOTH SIDES.
- CENTER BUSHING/SLEEVE ASSY (ITEM 12) IN OUTER SLEEVE (ITEM 15). WELD 1.0 AT 4 PLACES, BOTH SIDES. ALLOW STEEL TO COOL BETWEEN WELDS TO PREVENT DAMAGING THE BOND BETWEEN THE RUBBER BUSHING AND STEEL SLEEVE. ALSO STAGGER WELDS TO PREVENT HEAT BUILDUP AND DISTORTION BY WELDING TOP OF SLEEVE AT OUTSIDE OF FRAME THEN INSIDE OF FRAME AT BOTTOM OF SLEEVE, MOVING AROUND THE SLEEVE IN 90° INCREMENTS.

CLEARANCE SPECIFICATIONS:

- 1.5 INCH MINIMUM CLEARANCE REQUIRED BETWEEN TOP OF TIRE AND BOTTOM OF TRAILER STRUCTURE WHEN AXLE IS AT BUMPER CONTACT.
- 2.0 INCHES MINIMUM CLEARANCE REQUIRED BETWEEN INSIDE OF TIRE AND TRAILER STRUCTURE FOR LATERAL MOVEMENT.
- 0.75 INCH MINIMUM CLEARANCE MUST BE MAINTAINED AROUND AIR SPRING WHEN IT IS AT MAXIMUM DIAMETER.

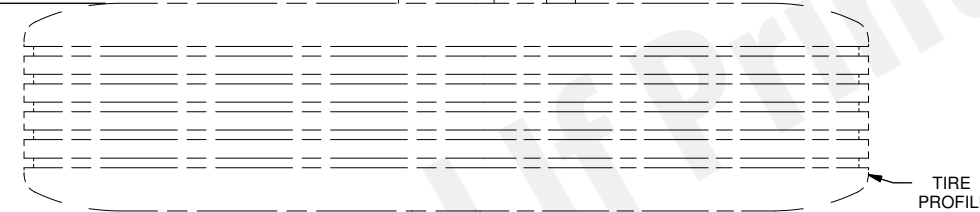
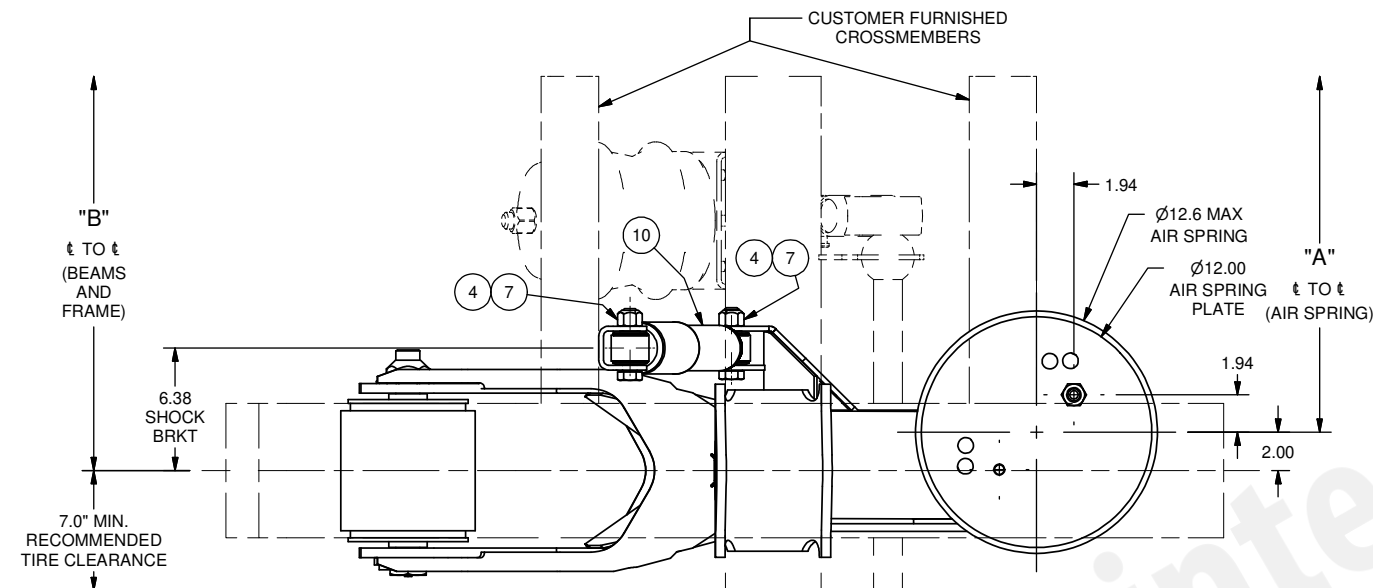

ITEM 15: 7.0 O.D. SLEEVE THROUGH TRAILER FRAME (SEE NOTES)

SECTION B-B (SOME ITEMS NOT SHOWN FOR CLARITY)

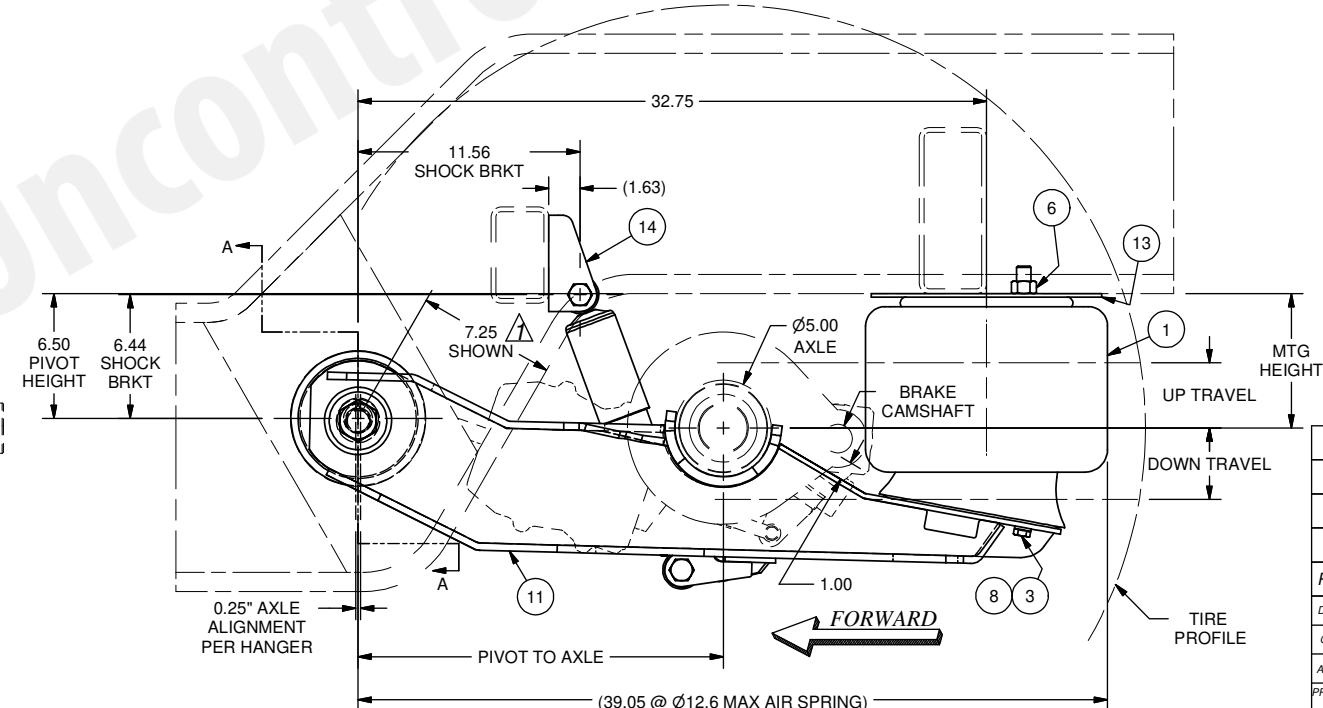
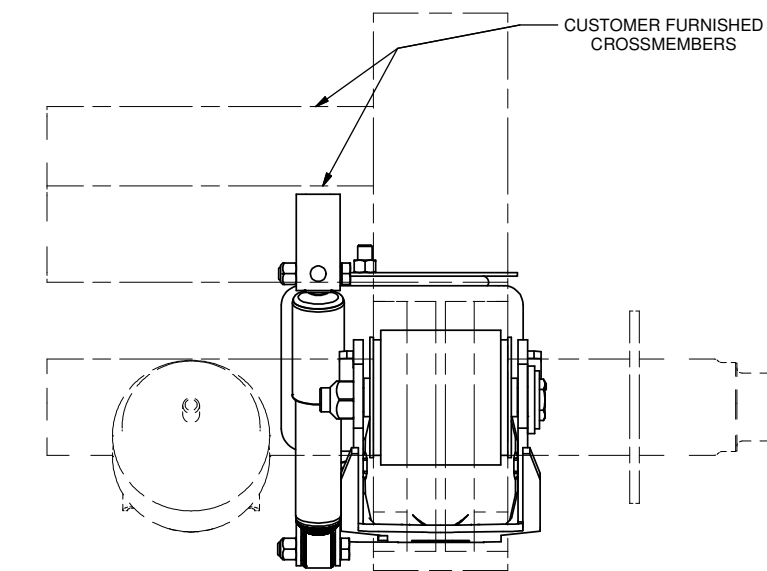
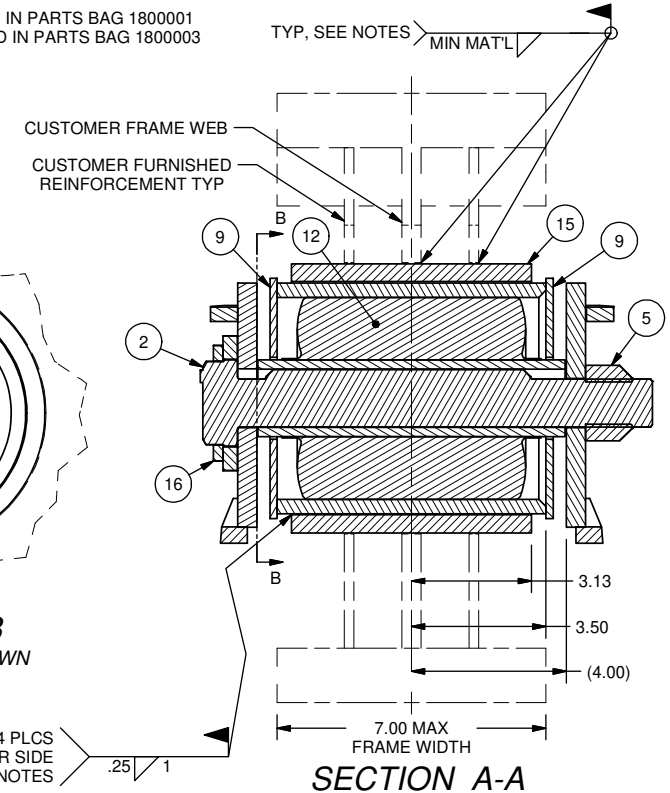

7 INCH MOUNTING HEIGHT SHOWN

TYPICALLY USED WITH 2400306 UNDERSLUNG SUSPENSION FOR ADDITIONAL AXLES

PARTS REQUIRED FOR 6000073 (CARTON OF PARTS)		PARTS REQUIRED FOR BEAMS (LH/RH)		
ITEM	PART NO.	DESCRIPTION	QTY	QTY
1	1001R12692G	AIR SPRING 1R12-692	2	
2	1137694B001	ECCENTRIC BOLT (FORGED) 10.75"	2	
3	1145383B105	HHCS 1/2" 13NC 1-1/4" L GRADE 5, ZINC PLATE	6	
4	1147698B105	HHCS 3/4" 10NC 3-1/4" L GRADE 5, ZINC PLATE	4	
5	1150033	L'NUT 1-1/4"-7UNC -2B HVY	2	
6	1150558B102	NUT 3/4" 16NF GRD 2	2	
7	1150709B105	L'NUT 3/4" 10NC OVAL 3/4" HI WAX	4	
8	1160556B100	L'WASHER 1/2" S/T MED ZINC PLATE	6	
9	1167680B000	WEAR WASHER, UHMW-PE, BLACK	4	
10	1270563B003	SHOCK ASSY 6" MONROE	2	
11	4287716D101	BEAM ASSY - LH	1	
	4287716D201	BEAM ASSY - RH	1	
12	5450022	BUSHING ASSY BONDED YOKE	2	
13	7000407	AIR SPRING MOUNTING PLATE	2	
14	8147716B000	SHOCK BRACKET (FORMED)	2	
15	9097716B003	OUTER BUSH SLEEVE	2	
16	9003092B000	ANTI-TURN WASHER	2	

* ITEMS ARE INCLUDED IN PARTS BAG 1800001
 ** ITEMS ARE INCLUDED IN PARTS BAG 1800003

TYP. SEE NOTES MIN MAT'L

TYP .4 PLCS PER SIDE SEE NOTES

TRACK WIDTH (IN)	71.50	77.50
DIMENSION "A" (IN)	31.00	37.00
DIMENSION "B" (IN)	35.00	41.00

MODEL NUMBER	MTG HEIGHT	UP TRAVEL	DOWN TRAVEL	PIVOT TO AXLE
RAR-240W-1-7-25-USW	6.0"	2.4"	4.7"	19.02"
	6.5"	2.9"	4.2"	19.03"
	7.0"	3.4"	3.7"	19.02"
	7.5"	3.9"	3.2"	19.01"

REV	PROJ / ECR	DESCRIPTION	DATE	BY	CHK	APPD
K	1986	UPDATED ITEM 12, ITEM 15 WAS 8990027	3/4/21	CAG	AAS	CJB
J	1568	ITEM 1 WAS 1000003	12/27/19	CAG	AAS	CJB
H	19101	REMOVED 301 ASSEMBLY LEVEL, PER ECR B182	01/17/2019	GWH	AAS	CJB
G	17101	CORRECTED ITEM 2 BOLT LENGTH TYPO (WAS 9.5")	6/14/17	AAS	MDJ	CJB

YOKE BEAM AND ALL AXLE AND BRAKE COMPONENTS MUST CLEAR TRAILER STRUCTURE THROUGHOUT THE ENTIRE RANGE OF TRAVEL OF THE SUSPENSION

This drawing and/or electronic media containing this drawing is the sole property of the Ridewell Corp. and is loaned with the express condition that it is not to be used in any way deleterious to the interest of the Ridewell Corp. The acceptance of this drawing and/or electronic media containing this drawing will be construed as an acceptance of the foregoing conditions. Drawings and/or electronic media containing this drawing are to be returned to the Ridewell Corp. upon request.

RIDEWELL CORPORATION
 PO BOX 4586 SPRINGFIELD, MISSOURI 65808

25,000 LB. CAPACITY
YOKE SUSPENSION
RAR-240W-1-7-25-USW

SHEET 1 OF 1 PART NO: 2400407 REV: K

TOLERANCES UNLESS OTHERWISE SPECIFIED:
 DECIMAL: .XX ± 0.06 ANG: X ± 1°
 .XXX ± 0.030 (XXX) KCC
 *WELD TOLERANCES PER ISO W045-02