

**AXLE ADJUSTMENT PROCEDURE:**

- AXLE ALIGNMENT SHALL BE IN ACCORDANCE WITH SAE OR TMC RECOMMENDED STANDARDS.
- LOOSEN PIVOT NUT.
- USING 1/2" DRIVE BREAKER BAR, ROTATE ADJUSTER PLATE IN THE DIRECTION OF DESIRED AXLE MOVEMENT.
- ENSURE THAT THE ADJUSTER PLATE AND ALIGNMENT WASHER HAVE MOVED IN UNISON. IT IS IMPORTANT THAT THE BUSHING IS NOT SKEWED IN THE HANGER PRIOR TO TIGHTENING.
- SNUG PIVOT FASTENERS AND RECHECK ALIGNMENT.
- TORQUE PIVOT BOLT USING A 1" DRIVE IMPACT WRENCH AND #6100054 E-20 TORX SOCKET (OR EQUIVALENT) UNTIL THE TORX HEAD SHEARS OFF FROM THE BOLT.
- WELDING OF ADJUSTER PLATES OR ALIGNMENT WASHERS TO THE HANGER SIDEWALLS IS NOT REQUIRED OR RECOMMENDED.

ITEM	SIZE	TORQUE	
		(FT-LB)	(N-M)
PIVOT BOLT/NUT	7/8-9	SEE ABOVE	SEE ABOVE
SHOCK BOLT/NUT	3/4-10	200-230	271-312
AIR SPRING Ø 0.75 FASTENERS	3/4-16	45-50	61-68
AIR SPRING Ø 0.50 FASTENERS	1/2-13	25-30	27-34

**NOTES:**

- MAIN PIVOT FASTENERS WILL BE SHIPPED WITH MINIMAL TORQUE APPLIED. IT IS THE INSTALLER'S RESPONSIBILITY TO PROPERLY TORQUE THESE FASTENERS AFTER AXLE IS ALIGNED.
- TORQUE VALUES REFLECT LUBRICATED THREAD CONDITION (NUTS ARE PRE-LUBED).
- SUSPENSION FASTENERS TO BE RETORQUED INITIALLY AT 6,000 MILES (9,656 KM) AND 50,000 MILES (80,467 KM) INCREMENTS THEREAFTER. DO NOT RETORQUE PIVOT FASTENERS.
- FOR BUSHING REPLACEMENT ORDER KIT #6040098; BUSHING INSTALLATION TOOL #6100051 CAN BE USED.
- FOR AXLE TO SUSPENSION WELDING SEE RIDEWELL WELD PROCESS #1
- SUGGESTED CROSSMEMBER LOCATION AND SIZE ARE GIVEN. SIZE AND SHAPE MAY VARY WITH THE TRAILER DESIGN AND ARE THE RESPONSIBILITY OF THE TRAILER OEM.
- STATED DOWN TRAVEL REFLECTS SUSPENSION WITH SHOCK ABSORBERS AT MAXIMUM EXTENSION AND WITH UNPRESSURIZED AIR SPRINGS. STATED UP TRAVEL REFLECTS SUSPENSION WITH AIR SPRINGS AT BUMPER CONTACT.
- STATED CAPACITY RATING FOR SUSPENSION ONLY. RATING OF AXLE, BRAKES, AND WHEEL END EQUIPMENT PER MANUFACTURER.
- CONTACT RIDEWELL FOR AIR CONTROL KIT OPTIONS.
- INSTALLER MUST SET THE SUSPENSION TO THE SPECIFIED MOUNTING HEIGHT BEFORE TORQUING THE PIVOT BOLT TO PREVENT PRE-LOADING THE RUBBER IN THE BUSHING.

**CLEARANCE SPECIFICATIONS:**

- 1.5 INCH MINIMUM CLEARANCE REQUIRED BETWEEN TOP OF TIRE AND BOTTOM OF TRAILER STRUCTURE WHEN AXLE IS AT BUMPER CONTACT.
- 2.0 INCHES MINIMUM CLEARANCE REQUIRED BETWEEN INSIDE OF TIRE AND TRAILER STRUCTURE FOR LATERAL MOVEMENT.
- 0.75 INCH MINIMUM CLEARANCE MUST BE MAINTAINED AROUND AIR SPRING WHEN IT IS AT MAXIMUM DIAMETER.

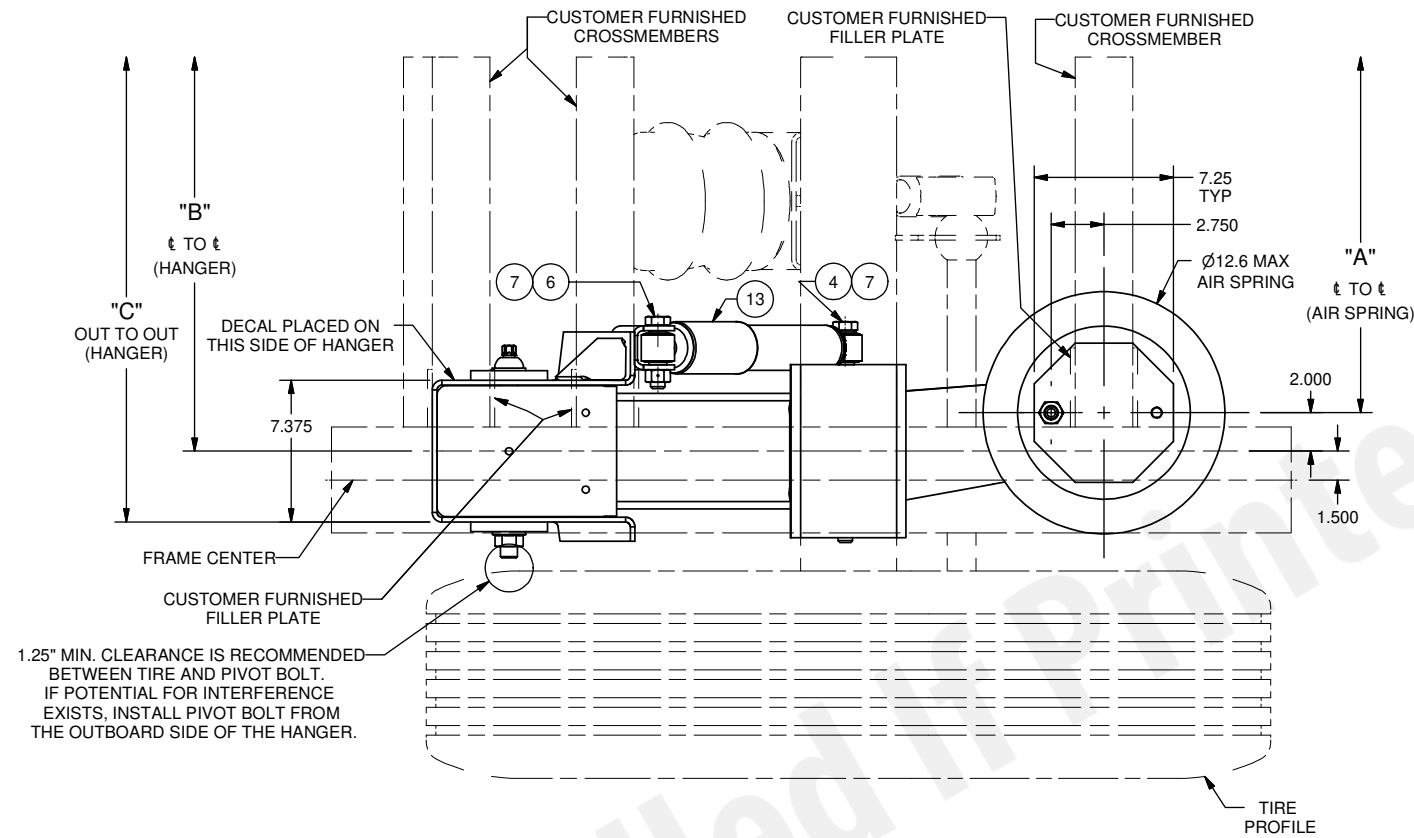

PARTS REQUIRED FOR 6000194 (CARTON OF PARTS)					
PARTS REQUIRED FOR 3011083 (RH HGR/LBA)					
PARTS REQUIRED FOR 3011082 (LH HGR/LBA)					
ITEM	PART NO.	DESCRIPTION	QTY	QTY	QTY
1	1001R12692G	AIR SPRING 1R12-692			2
2	1110084	BUSH CAVITY TENNECO MB96B914260	1	1	
3	1130031	PIVOT BOLT RD HD SHEAR-TYPE	1	1	
4	1140022	HHCS 3/4" 10NC 11"LG GR8 ZN			2
5	1145383B105	HHCS 1/2" 13NC 1-1/4"L GRADE 5, ZINC PLATE			6
6	1147698B105	HHCS 3/4" 10NC 3-1/4"LG GRADE 5, ZINC PLATE			2
7	1150023	L'NUT 3/4"-10NC CENTER LOCK GR-B			4
8	1150067	L'NUT 7/8" 9UNC 2B FL/TL GrG ZNC	1	1	
9	1150558B102	NUT 3/4" 16NF GRD 2			2
10	1160021	WEAR WASHER UHMW-PE MODEL 260	2	2	
11	1160556B100	L'WASHER 1/2" S/T MED ZINC PLATE			6
12	1160036	WASHER 7/8" F436 ZINC/COATED	1	1	
13	1270563B000	SHOCK ASSY 6" MONROE			2
14	3260502	HANGER ASSY - LH	1		
	3260503	HANGER ASSY - RH		1	
15	4280268	BEAM ASSY - LH	1		
	4280269	BEAM ASSY - RH		1	
16	7001723B000	A/SPG PLATE 7-1/4" OCTAGON			2
17	7002249	ALIGNMENT WASHER 4.0"OD	1	1	
18	7002686	ADJUSTER PLATE 4.0"OD	1	1	

REFERENCE NOTE FOR ORDERING BEAM/BUSH ASSY:  
5970430 - LH BEAM/BUSH ASSEMBLY (SHOWN)  
5970431 - RH BEAM/BUSH ASSEMBLY (OPPOSITE)

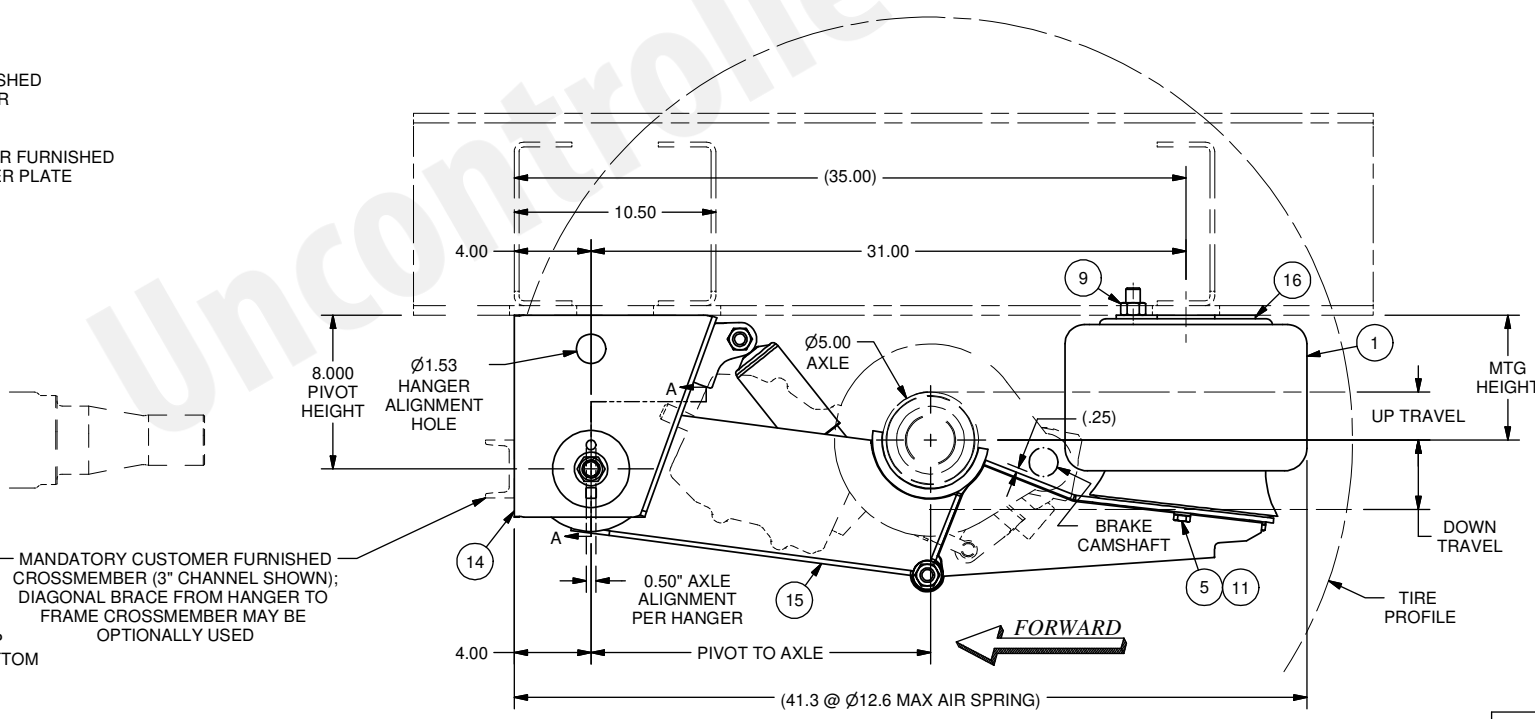
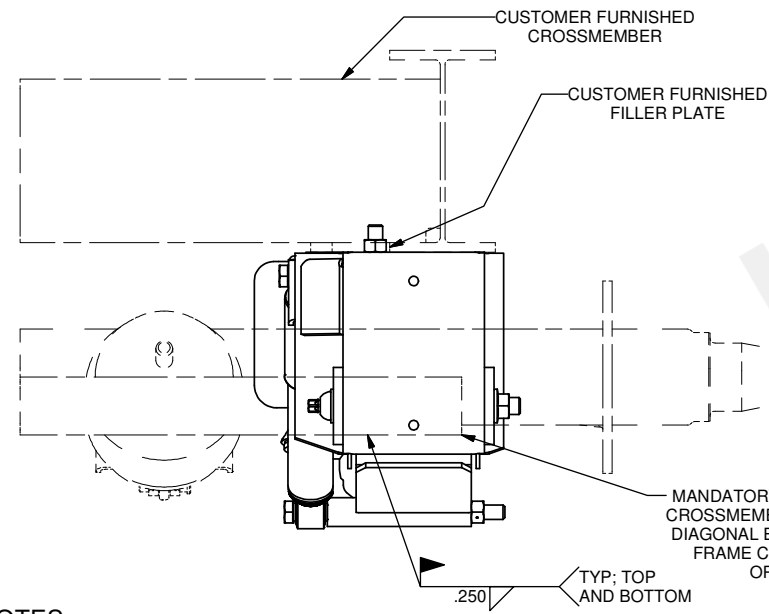
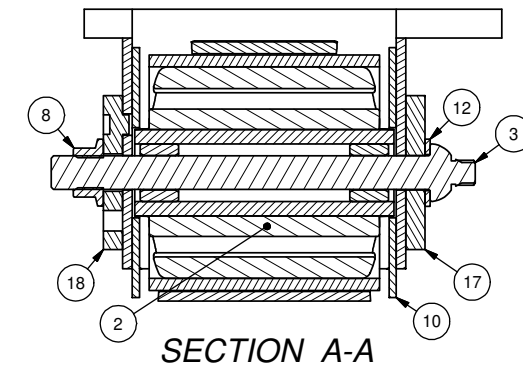

TRACK WIDTH (IN)	71.50	77.50
DIMENSION "A" (IN)	31.00	37.00
DIMENSION "B" (IN)	35.00	41.00
DIMENSION "C" (IN)	42.38	48.38

MODEL NUMBER	MTG HEIGHT	UP TRAVEL	DOWN TRAVEL	PIVOT TO AXLE
RAR-260-1-6.75-25-USW	6.5"	2.5"	3.6"	17.69"
	7.0"	3.0"	3.1"	17.72"
	7.5"	3.5"	2.6"	17.74"

- NOTES:**
- FAILURE TO BRACE HANGERS FOR LATERAL LOADS VOIDS WARRANTY.

This drawing and/or electronic media containing this drawing is the sole property of the Ridewell Corp. and is loaned with the express condition that it is not to be used in any way deleterious to the interest of the Ridewell Corp. The acceptance of this drawing and/or electronic media containing this drawing will be construed as an acceptance of the foregoing conditions. Drawings and/or electronic media containing this drawing are to be returned to the Ridewell Corp. upon request.

DRAWN BY:	CAG	6/15/2020
CHECKED:	AAS	6/15/2020
APPROVED:	CJB	6/15/2020
PROJECT NO:	1934	
MATERIAL:	SEE B.O.M.	

**RIDEWELL CORPORATION**  
PO BOX 4586 SPRINGFIELD, MISSOURI 65808

**25,000 LB. CAPACITY  
UNDERSLUNG SUSPENSION  
RAR-260-1-6.75-25-USW**

REV	PROJ / ECR	DESCRIPTION	DATE	BY	CHK	APPD
A	2156	UPDATED ITEM 14 (SHOCK BRKT)	4/21/21	CAG	GWH	CJB

TOLERANCES UNLESS OTHERWISE SPECIFIED:  
DECIMAL: X ± 0.1 FRACTION: ± 1/16  
XX ± 0.06 ANG: X ± 1'  
XXX ± 0.030 XXXX KCC  
\*WELD TOLERANCES PER ISO W045-02

SHEET 1 OF 1 PART NO: 2609206 REV: A