

**PLUNGER DETAIL**

**NOTES:**

- ▲ LOCATIONS FOR GREASE.
- ▲ USE RIDEWELL AXLE ASSEMBLY PROCEDURE 9710005.
- ▲ FOR WHEEL END BEARING AND SEAL ASSEMBLY PROCEDURE, SEE DWG 9710011.
- ▲▲ NON-STEER LOCK APPLICATION REQUIRES 7 (ITEM 4) PER WHEEL (NO ITEM 5 USED).
- ▲▲ REFER TO INSTALLATION INSTRUCTIONS 9710004.

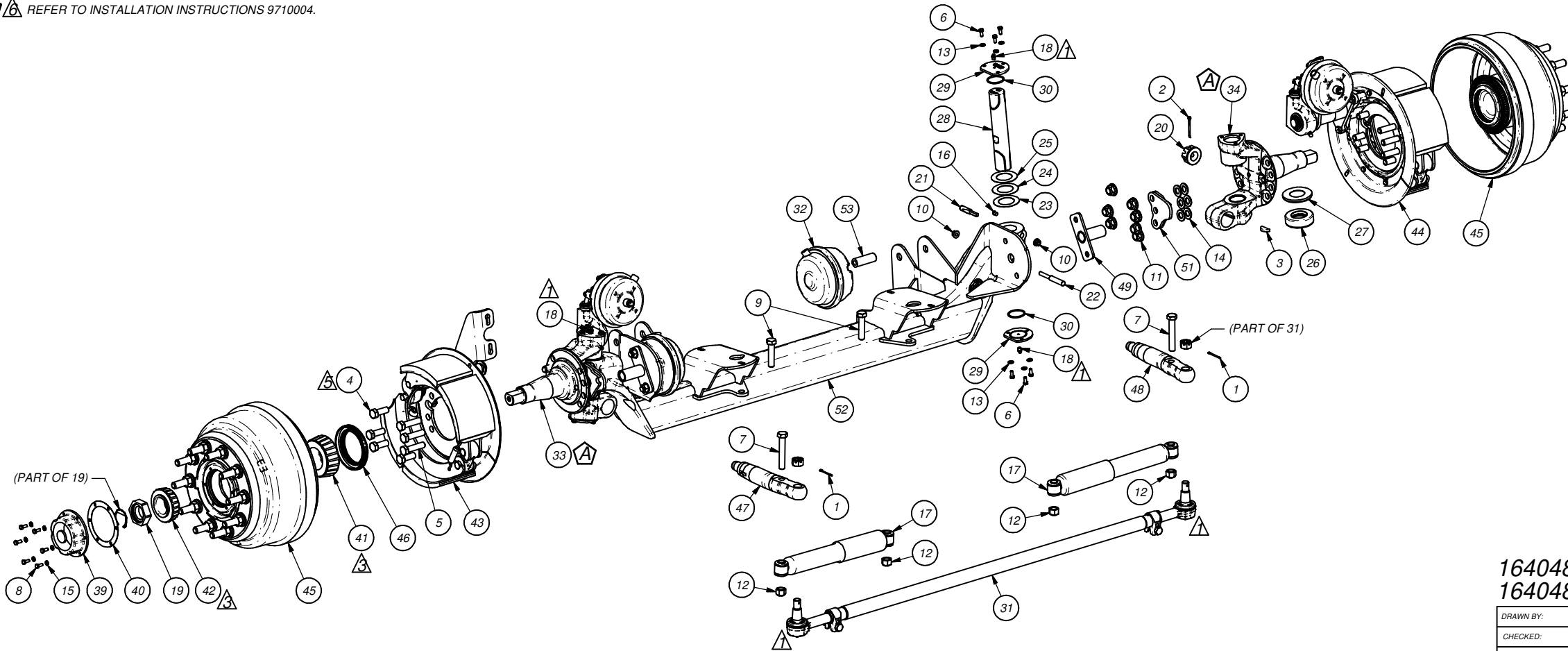
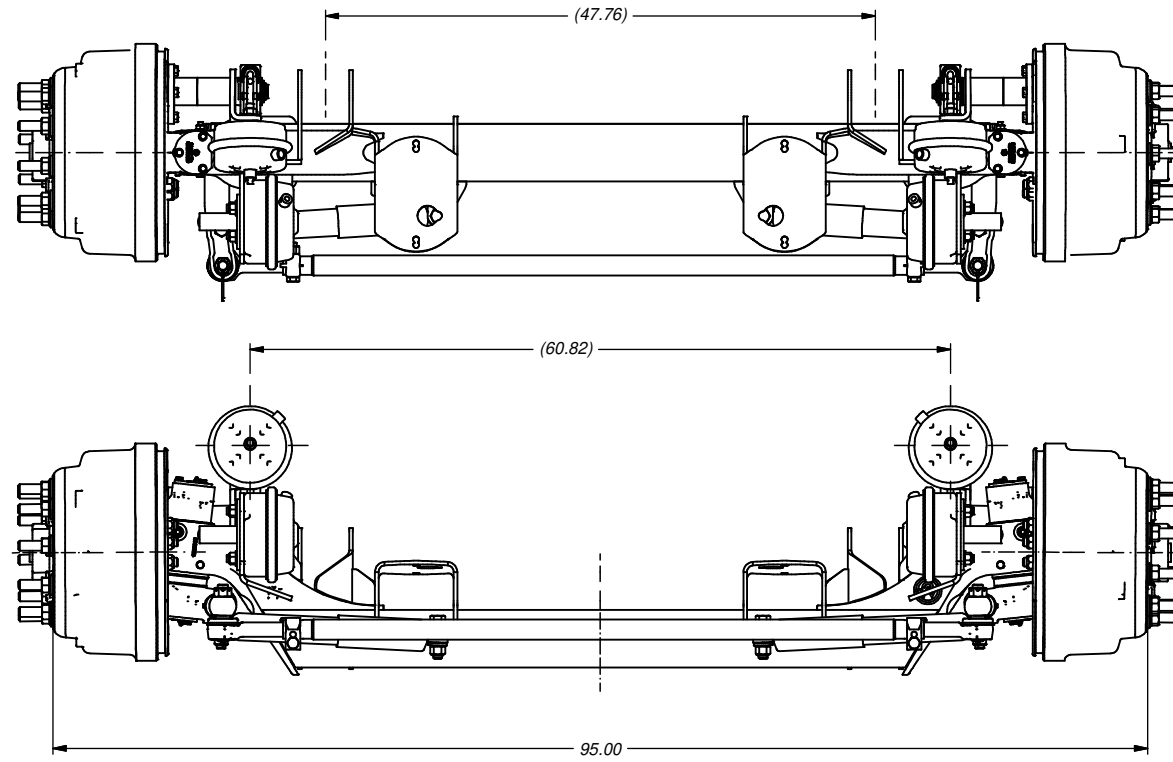
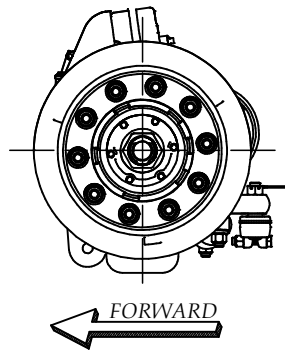

PARTS REQUIRED FOR 1640481(S) (w/STEER LOCK)		PARTS REQUIRED FOR 1640481 (NON STEER LOCK)		
ITEM	PART NO.	DESCRIPTION	QTY	QTY
1	1130004	COTTER PIN 9/64"x1-3/4	2	2
2	1137409B002	COTTER PIN 3/16"x2-1/4	2	2
3	1137409B003	WOODRUFF KEY #25 143699-0108627	2	2
4	1140057	HHCS 3/4" 16NF 2" LG GRD 8 ZINC PLATE	14	8
5	1140059	HHCS 3/4" 16NF 3.00" LG GRD 8 ZINC PLATE	-	6
6	1140064	HHCS 5/16" 18NC 3/4"L GR8 ZN	12	12
7	1143076B105	HHCS 3/4" 10NC 4-1/2"L	2	2
8	1144206B105	HHCS 5/16" 18NC 3/4"LG GRADE 5, ZINC PLATE	12	12
9	1147698B105	HHCS 3/4" 10NC 3-1/4LG	2	2
10	1150001	L'NUT 7/16-20 FLANGED T-L, GRADE 5 (B)	4	4
11	1150016	L'NUT 3/4-16NF FL-TL GRADE 8 (G) ZINC PLATED	14	14
12	1150709B105	L'NUT 3/4" 10NC OVL 3/4"HI WAX	4	4
13	1160004	WASHER 5/16" SAE FLAT, PLATED ZINC PLATING	12	12
14	1160576B100	WASHER 3/4" SAE FLAT, ZINC PLT	-	12
15	1164263B100	L'WASHER 5/16 MED ZINC PLATE	12	12
16	1234250B324	PLUG 1/8 MNPT HEX HEAD	4	4
17	1310002	STEERING STABILIZER w/SPRING	2	2
18	1660134	FITTING GREASE, 1/8" MPTF FF/FG	4	4
19	1660188	SPINDLE NUT FL SER. #448-4865	2	2
20	1660190	NUT, CASTLE 1-1/4" 12UNF FL941	2	2
21	1660216	DRAW KEY, 3.188L x 7/16-20NF	2	2
22	1660217	LOCK PIN .44/20 4.75" 20k 232	2	2
23	1660218	SHIM, KING PIN .005" THK FL-943	2	2
24	1660219	SHIM, KING PIN .015" THK FL-943	2	2
25	1660220	SHIM, KING PIN .030" THK FL-943	2	2
26	1660224	BEARING ASS'Y T-208 FL-943	2	2
27	1660225	THRUST BEARING SEAL, T-208, FL WESTPORT	2	2
28	1660231	KING PIN FL SERIES (KAISER)	2	2
29	1660232	KING PIN END CAP KAISER 20K	4	4
30	1660233	O'RING END CAP SEAL KAISER 20K	4	4
31	1660237	TIE ROD 20K 63.74"LG	1	1
32	1660243	BRAKE CHAMBER, MGM C30L3 X=1.625	-	2
33	1660698	KNUCKLE ASY LH W/ABS & KAISER BUSH	1	1
34	1660699	KNUCKLE ASY RH W/ABS & KAISER BUSH	1	1
35	NOT USED	NOT USED	-	-
36	NOT USED	NOT USED	-	-
37	1664702B002	BUSH -ABS #8997598154 WABCO RETAIN'G BUSH	2	2
38	1664702B010	ABS SENSOR #300151 (BENDIX) STR 1700mm LG	2	2
39	1667537B005	HUB CAP 16"20K 5.5"BC STEMCO 343-4249	2	2
40	1667537B006	GASKET H/C 5.5" B.C. #330-3122	2	2
41	1667726B004	WHEEL BEARING, INNER, 20K	2	2
42	1667726B005	WHEEL BEARING, OUTER 20K	2	2
43	1667726B009	BRAKE ASS'Y - LH 16.5x6 Q+ BAF 62	1	1
44	1667726B010	BRAKE ASS'Y - RH 16.5x6 Q+ BAF 62	1	1
45	1667726B018	HUB & DRUM HP #25301KV6T 16.5x6	2	2
46	1667726B030	BEARING SEAL INNER, 20K	2	2
47	1740020	TIE ROD ARM, LH 232-20K (WESTPORT)	1	1
48	1740021	TIE ROD ARM, RH 232-20K (WESTPORT)	1	1
49	4660052	STEER LOCK TUBE ASSY.	-	2
50	5340025	STOP ASS'Y LH STEER LOCK 20k	-	1
51	5340026	STOP ASS'Y RH STEER LOCK 20k	-	1
52	5640009	FAXL 233 20k 5.0 x 71.5 WT	1	-
	5640009S	FAXL 233 20k 5.0 X 71.5 WT w STEER LOCK OPT	-	1
53	9290015	STEER LOCK PLUNGER	-	2

1640481 - NOT SHOWN  
 1640481S - SHOWN

DRAWN BY:	AAS	7/22/2020
CHECKED:	BB	7/22/2020
APPROVED:	MJK	7/22/2020
PROJECT NO:	1956	
SCALE:	B - SIZE D - SIZE	NTS N/A
MATERIAL:	SEE BOM	1304.84 lbmass

**RIDEWELL CORPORATION**  
 PO BOX 4586 SPRINGFIELD, MISSOURI 65808

**AXLE 233 20K TRAILER 5.0x65.5  
 KAISER KING PIN WIDE TRACK  
 w/ABS SENSOR**

This drawing and/or electronic media containing this drawing is the sole property of the Ridewell Corp. and is loaned with the express condition that it is not to be used in any way deleterious to the interest of the Ridewell Corp. The acceptance of this drawing and/or electronic media containing this drawing will be construed as an acceptance of the foregoing conditions. Drawings and/or electronic media containing this drawing are to be returned to the Ridewell Corp. upon request.

A	2521	ITEM 33 WAS 1660281, 34 WAS 1660282, 35 WAS 1660315, 36 WAS 1660316, DELETED NOTE 4, REVISED NOTE 6	1/17/22	AAS	GWH	MJK		
REV	PROJ / ECR	DESCRIPTION	DATE	BY	CHK	APPD		